

Operating instructions

PLANETARY MONO MILL

PULVERISETTE 6 *classic line*

Valid starting with: 06.2000/03438



Read the instructions prior to performing any task!

Translation of the original operating instructions



Fritsch GmbH
Milling and Sizing
Industriestrasse 8
D - 55743 Idar-Oberstein
Telephone: +49 6784 70-0
Email: info@fritsch.de
Internet: www.fritsch.de

Certifications and CE conformity

Certification

Fritsch GmbH has been certified by the SGS-TÜV Saar GmbH.



An audit certified that Fritsch GmbH conforms to the requirements of the DIN EN ISO 9001:2015.

CE Conformity

The enclosed Conformity Declaration lists the guidelines the FRITSCH instrument conforms to, to be able to bear the CE mark.



Table of contents

1	Basic structure.	7
2	Safety information and use.	8
	2.1 Requirements for the user.	8
	2.2 Scope of application.	8
	2.2.1 Operating principle.	9
	2.2.2 Drive motor and speed regulation.	9
	2.3 Obligations of the operator.	9
	2.4 Information on hazards and symbols used in this manual.	10
	2.5 Device safety information.	12
	2.6 Protective equipment.	13
	2.6.1 Opening the hood without mains connection.	13
	2.6.2 Imbalance switch.	14
	2.7 Hazardous points.	15
	2.8 Electrical safety.	16
	2.8.1 General information.	16
	2.8.2 Protection against restart.	16
	2.8.3 Overload protection.	16
	2.8.4 Imbalance detection.	16
3	Technical data.	17
	3.1 Dimensions.	17
	3.2 Weight.	17
	3.3 Operating noise.	17
	3.4 Voltage.	17
	3.5 Current consumption.	17
	3.6 Power consumption.	17
	3.7 Protection class.	17
	3.8 Electrical fuses.	17
	3.9 Material.	18
	3.10 Final fineness.	18
4	Installation.	19
	4.1 Transport.	19
	4.2 Unpacking.	19
	4.3 Setting up.	19
	4.4 Ambient conditions.	20

4.5	Electrical connection.	21
4.5.1	Adjusting the mains voltage.	22
4.6	Setting device specifications.	23
5	Initial start-up.	24
5.1	Switching on.	24
5.2	Function check.	24
6	Using the device.	25
6.1	Choice of grinding bowls and grinding balls.	25
6.1.1	Size of the grinding balls.	26
6.1.2	Recommended number of balls per grinding bowl (independent of the material quantity).	28
6.1.3	Average calculated weight of a ball.	29
6.2	Filling quantities of grinding bowls.	29
6.3	Filling the grinding bowl.	30
6.4	Factors with an impact on grinding.	30
6.4.1	Running time (grinding duration).	30
6.4.2	Speed.	31
6.4.3	Reverse mode.	31
6.4.4	Number and size of the balls.	31
6.4.5	Weight of the balls (type of material).	31
6.4.6	Dry grinding.	32
6.4.7	Wet grinding (grinding in a suspension).	32
6.5	Clamping the grinding bowls.	33
6.5.1	Clamping with the "Safe-Lock" (5) tensioning device.	33
6.5.2	Clamping the 80 ml grinding bowls.	35
6.6	Mass balance.	36
6.7	Grinding duration.	36
6.8	Settings on the control panel.	37
6.8.1	Setting the speed.	37
6.8.2	Setting the running time.	38
6.9	Repetition of grinding / pause cycles.	39
6.10	Reverse mode.	39
6.11	Conducting a grinding operation.	40
6.11.1	Overload.	40
6.11.2	Switching off.	40
6.12	Cooling the grinding bowl.	41
6.13	Stand-by.	41

Table of contents

7	Accessories.	42
7.1	Additional clamping system for grinding harmful substances or in a gas atmosphere.	42
7.1.1	Locking the additional clamping system into place.	42
7.2	Grinding in inert gas with gassing lid.	46
7.2.1	Preparation for gassing.	46
7.2.2	Gassing.	47
7.2.3	Ventilate after grinding.	47
7.2.4	Cleaning the valves.	48
7.2.5	Installing valve inserts.	48
7.3	EASY GTM Gas Pressure and Temperature Measuring System.	49
7.3.1	Case contents and system design.	50
7.3.2	Inserting / changing the battery.	50
7.3.3	Configuration of transmitter ID and data transmission frequency.	53
7.3.4	Installation of the transmission unit on the EASY GTM bowl.	54
7.3.5	Inserting the EASY GTM system.	55
7.3.6	Cleaning the EASY GTM system.	57
7.3.7	Battery arrangement.	58
8	Cleaning.	60
8.1	Grinding elements.	60
8.2	Device.	60
9	Maintenance.	61
10	Repairs.	63
10.1	Checklist for troubleshooting.	63
11	Examples of comminution tasks.	65
12	Disposal.	68
13	Guarantee terms.	69
14	Safety logbook.	71
15	Index.	73

1 Basic structure



- | | |
|---------------------|------------------------------|
| 1 Hood handle | 8 Bowl holder |
| 2 Latch | 9 Voltage rotary switch |
| 3 Hood | 10 Main switch |
| 4 Membrane keyboard | 11 Mains connection |
| 5 Safe-Lock | 12 Circuit breaker 2x 10 A T |
| 6 Counter weight | 13 RS232 - interface |
| 7 Lock | 14 Support disc |

2 Safety information and use

2.1 Requirements for the user

This operating manual is intended for persons assigned with operating and monitoring the Fritsch PULVERISETTE 6. The operating manual and especially its safety instructions are to be observed by all persons working on or with this device. In addition, the applicable rules and regulations for accident prevention at the installation site are to be observed. Always keep the operating manual at the installation site of the PULVERISETTE 6.

People with health problems or under the influence of medication, drugs, alcohol or exhaustion must not operate this device.

The PULVERISETTE 6 may only be operated by authorised persons and serviced or repaired by trained specialists. All commissioning, maintenance and repair work may only be carried out by technically qualified personnel. Qualified personnel are persons who, because of their education, experience and training as well as their knowledge of relevant standards, regulations, accident prevention guidelines and operating conditions, are authorised by those responsible for the safety of the machine to carry out the required work and are able to recognize and avoid possible hazards as defined for skilled workers in IEC 364.

In order to prevent hazards to users, follow the instructions in this manual.

Malfunctions that impair the safety of persons, the PULVERISETTE 6 or other material property must be rectified immediately. The following information serves both the personal safety of operating personnel as well as the safety of the products described and any devices connected to them: All maintenance and repair work may only be performed by technically qualified personnel.

This operating manual is not a complete technical description. Only the details required for operation and maintaining usability are described.

Fritsch has prepared and reviewed this operating manual with the greatest care. However, no guarantee is made for its completeness or accuracy.

Subject to technical modifications.

2.2 Scope of application



NOTICE

This laboratory instrument is designed for an 8-hour shift operation at 30 % duty cycle and not for continuous operation.

The duty cycle is defined as the ratio of load duration to run time. The run time is defined as load duration plus pause time. According to DIN EN 60034-1 (VDE 0530, IEC34-1) a continuous operation already takes place after a standardised run time of 10 minutes. At 30 % duty cycle (DC = ratio of load duration to run time) a load duration of 3 minutes and a pause time of 7 minutes would be within standard.

If the standardised run time of 10 minutes is exceeded, then, by definition, there would be a continuous operation and disproportionate temperature increases may occur, possibly involving increased wear.

The Planetary mono mill PULVERISETTE 6 *classic line* can be applied universally for the fast, dry or wet grinding of inorganic and organic samples for analysis, quality inspection, material testing or mechanical alloying. During synthesis, the PULVERISETTE 6 mixes and homogenises dry samples, emulsions or suspensions.

2.2.1 Operating principle

The grinding stock is crushed and ground by grinding balls in a grinding bowl. The centrifugal forces resulting from the rotation of the grinding bowls around their own axes and from the rotating support disc (14) influence the contents of the grinding bowl consisting of grinding stock and grinding balls.

The grinding bowl and the support disc (14) have opposite directions of rotation so that the influence of the centrifugal forces is alternately in the same direction and in the opposite direction. The result is that the grinding balls run down the inside of the bowl's wall as friction effect and the grinding balls hit the opposite wall of the grinding bowl as impact effect. The impact effect is amplified by the impact of the grinding balls against each other.

The loss-free comminution, even when grinding suspensions, is ensured by the hermetic seal between the grinding bowl and the lid.

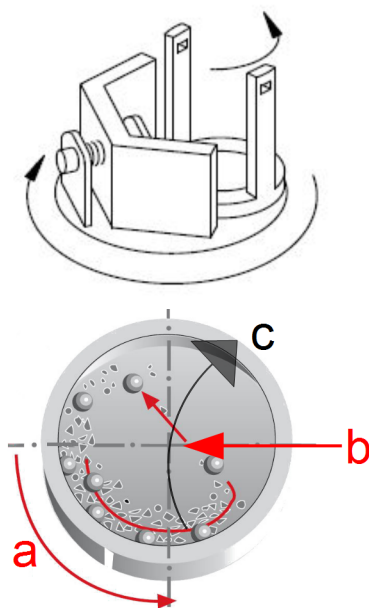

- a Rotation of the grinding bowl
- b Centrifugal force
- c Movement of the support disc

2.2.2 Drive motor and speed regulation

A maintenance-free three-phase motor operated via a frequency converter is used as the drive.

2.3 Obligations of the operator

Before using the PULVERISETTE 6, this manual is to be carefully read and understood. The use of the PULVERISETTE 6 requires technical knowledge; only commercial use is permitted.

The operating personnel must be familiar with the content of the operating manual. For this reason, it is very important that these persons actually receive the present operating manual. Ensure that the operating manual is always near the device.

The PULVERISETTE 6 may exclusively be used within the scope of applications set down in this manual and within the framework of guidelines put forth in this manual. In case of non-compliance or improper use, the customer assumes full liability for the functional capability of the PULVERISETTE 6 and for any damage or injury arising from failure to fulfil this obligation.

Safety information and use

By using the PULVERISETTE 6 the customer agrees with this and recognizes that defects, malfunctions or errors cannot be completely excluded. To prevent risk of damage to persons or property or of other direct or indirect damage, resulting from this or other causes, the customer must implement sufficient and comprehensive safety measures for working with the PULVERISETTE 6.

Neither compliance with this manual nor the conditions and methods used during installation, operation, use and maintenance of the PULVERISETTE 6 can be monitored by Fritsch GmbH. Improper execution of the installation can result in property damage and thus endanger persons. Therefore, we assume absolutely no responsibility or liability for loss, damage or costs that result from errors at installation, improper operation or improper use or improper maintenance or are in any way connected to these.

The applicable accident prevention guidelines must be complied with.

Generally applicable legal and other obligatory regulations regarding environmental protection must be observed.

2.4 Information on hazards and symbols used in this manual

Safety information

Safety information in this manual is designated by symbols. Safety information is introduced by keywords that express the extent of the hazard.



DANGER

This symbol and keyword combination points out a directly hazardous situation that can result in death or serious injury if not avoided.



WARNING

This symbol and keyword combination points out a possibly hazardous situation that can result in death or serious injury if not avoided.



CAUTION

This symbol and keyword combination points out a possibly hazardous situation that can result in slight or minor injury if not avoided.



NOTICE

This symbol and keyword combination points out a possibly hazardous situation that can result in property damage if not avoided.

Special safety information

To call attention to specific hazards, the following symbols are used in the safety information:



DANGER

This symbol and keyword combination points out a directly hazardous situation due to electrical current. Ignoring information with this designation will result in serious or fatal injury.



! DANGER

This symbol and keyword combination designates contents and instructions for proper use of the machine in explosive areas or with explosive substances. Ignoring information with this designation will result in serious or fatal injury.



! DANGER

This symbol and keyword combination designates contents and instructions for proper use of the machine with combustible substances. Ignoring information with this designation will result in serious or fatal injury.



! WARNING

This symbol and keyword combination points out a directly hazardous situation due to movable parts. Ignoring information with this designation can result in hand injuries.



! WARNING

This symbol and keyword combination points out a directly hazardous situation due to hot surfaces. Ignoring information with this designation can result in serious burn injuries due to skin contact with hot surfaces.

Safety information in the procedure instructions

Safety information can refer to specific, individual procedure instructions. Such safety information is embedded in the procedure instructions so that the text can be read without interruption as the procedure is being carried out. The keywords described above are used.

Example:

1. ➔ Loosen screw.

2. ➔



CAUTION

Risk of entrapment at the lid.

Close the lid carefully.

3. ➔ Tighten screw.

Tips and recommendations



This symbol emphasises useful tips and recommendations as well as information for efficient operation without malfunction.

2.5 Device safety information

Please observe!

- Only use original accessories and original spare parts. Failure to observe this instruction can compromise the safety of the machine.
- Safe conduct must be strictly observed during all work.
- All currently applicable national and international accident prevention guidelines must be complied with.



CAUTION

Wear hearing protection!

If a noise level of 85 dB(A) is reached or exceeded, ear protection should be worn to prevent hearing damage.



WARNING

The maximum accepted concentration (MAC) levels of the relevant safety guidelines must be observed; if necessary, ventilation must be provided or the machine must be operated under an extractor hood.



DANGER

Explosion hazard!

- When Grinding oxidisable substances, e.g. metal or coal, there is a risk of spontaneous combustion (dust explosion) if the proportion of fine particles exceeds a certain percentage. When Grinding these kinds of substances, special safety measures must be taken and the work must be supervised by a specialist.
- The device is not explosion-protected and is not suitable for Grinding explosive materials.
- Sample components might react with each other during grinding and lead to explosions.
- Reactants, substances (e.g. hydrogen) which are volatile and flammable can be spontaneously produced! The user must rule out such a reaction before grinding.

- Do not remove the information signs.



NOTICE

Immediately replace damaged or illegible information signs.

- Unauthorised alteration of the device will void Fritsch's declaration of conformity to European directives and void the guarantee.
- The PULVERISETTE 6 should only be used when it is in proper working order, as intended and in a safety- and hazard-conscious manner adhering to the operating manual. In particular, immediately rectify any malfunctions that could pose a safety hazard.
- If, after reading the operating manual, there are still questions or problems, please do not hesitate to contact our specialised personnel.

- Do not reuse damaged accessories.
- Do not leave the Planetary mono mill running for several hours without cooling phases. Risk of overheating!
- The mill must never be left running unsupervised. In certain operating states, the vibrations may result in a shifting effect on the surface.

2.6 Protective equipment



Protective equipment is to be used as intended and may not be disabled or removed.

All protective equipment is to be regularly checked for integrity and proper functioning.

For start-up, the hood (3) has to be closed.

The hood (3) is locked:

- without mains connection
- during operation



The hood (3) can only be opened, if the mill's drive is at standstill.

2.6.1 Opening the hood without mains connection



NOTICE

Use the emergency release only if a power failure or damage to the device prevents normal opening. Only open the emergency release gently and turn the triangular key 180 degrees clockwise. Any other manner of handling can damage the locking mechanism, rendering the mill unusable.

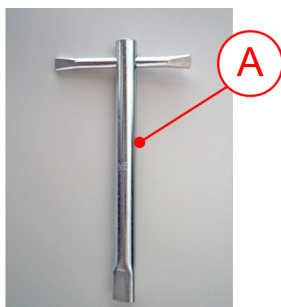

CAUTION

The emergency release must not be activated while the machine is running! Disconnect the machine from the mains before the emergency release. Failure to observe this will render void the guarantee, and releases us from liability for any resulting damage to the device or personal injury.

Safety information and use

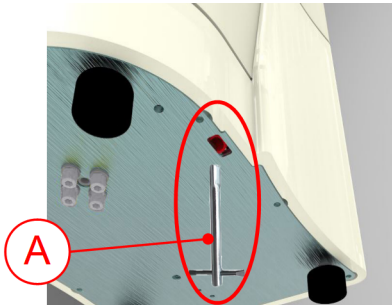

1. ➤ Insert the included triangular key (A) into the bore hole on the bottom side of the PULVERISETTE 6 *classic line* and turn it clockwise 180 degrees.
2. ➤ Unlock the latch (2) by pressing the hood handle (1).
3. ➤ The hood (3) can now be opened.
4. ➤ The mill can only be switched on again if the hood (3) is closed and the safety lock (7) has been reactivated by turning the triangular key 180 degrees anticlockwise.

2.6.2 Imbalance switch

The device switches off if there is excessive imbalance. If this is the case, then the counterweight has to be readjusted.



CAUTION

The imbalance switch can be disabled at your own risk. The Fritsch company will give no guarantee for damage resulting from disabling of the imbalance switch!



NOTICE

Change these settings only after all work as described in ➤ *Chapter 4 'Installation' on page 19* has been carried out!



In the default setting of the imbalance switch, it is activated!

Activation / deactivation of the imbalance switch in Setup mode:

1. ➤ Press and hold the STOP button on the front control panel.



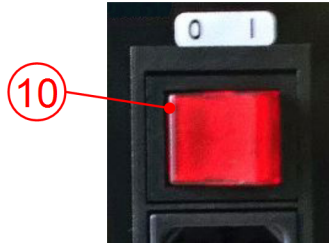

2. → Switch on the device with the main switch (10) on the back side of the device, and release the STOP button.



3. → If POWER SUPPLY is flashing, the device is in setup mode. If POWER SUPPLY is not flashing, repeat the procedure.

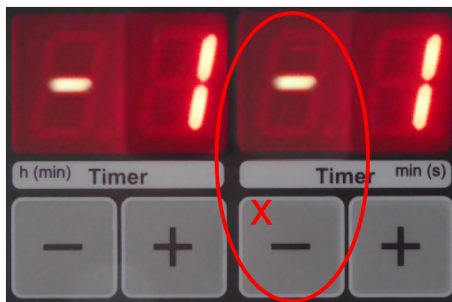

4. → **NOTICE**
- In the display above the right "-" button (x) in the TIMER field, there must be a minus sign. That activates the imbalance switch and prevents a drift of the device and possible damage to the device resulting from it. If the imbalance switch is deactivated, a '1' is shown.



5. → To save and end setup mode, press the STOP button.

2.7 Hazardous points



CAUTION

- Crushing hazard when closing the hood (3).
- Crushing hazard at the grinding bowl safe-lock tensioning device (5).
- Crushing hazard at the counterweight!

Safety information and use



CAUTION

Risk of splashes!

During wet grinding overpressure may have been formed by the high temperature.

Wear protective goggles!



CAUTION

Risk of burning!

The grinding bowls can be very hot after grinding.

Wear protective gloves!

2.8 Electrical safety

2.8.1 General information

- The main switch (10) separates the device from the mains on two poles.
- Switch off the main switch (10) if the planetary mono mill is down for a longer period of time (e.g. overnight).

2.8.2 Protection against restart

In case of power failure during operation or after switching off with the main switch (10), the hood (3) is locked. The hood lock (7) is opened when the power returns. For safety reasons, however, the mill does not restart.

2.8.3 Overload protection

- In the event of an overload, the device reduces the speed in a controlled manner. The REDUCED SPEED light is lit as a warning.
- The device switches off if the drive motor becomes too hot.
- The device switches off if the drive is blocked. (See ➔ *Chapter 10 'Repairs' on page 63*)

2.8.4 Imbalance detection

The device switches off if there is excessive imbalance. (see ➔ *Chapter 6.6 'Mass balance' on page 36* and)

3 Technical data

3.1 Dimensions

500 x 370 x 530 mm (height x width x depth)

3.2 Weight

Net: 63 kg

Gross: approx. 90 kg

3.3 Operating noise

Emissions value of workplace according to DIN EN ISO 3746:2005 is up to 85dB (A). The value fluctuates strongly, depending on the speed, the grinding stock, and the type of grinding bowl and grinding balls.

3.4 Voltage

The device can be operated in two voltage ranges:

- Single phase alternating current 100 - 120V \pm 10%, and,
- Single phase alternating current 200 - 240V \pm 10%.

(See also [Chapter 4.5 'Electrical connection'](#) on page 21)

Transient overvoltage according to overvoltage category II is permitted.

3.5 Current consumption

Depending on the mains voltage, the maximum current consumption is in the ranges:

- 100 - 120V \rightarrow 12 A
- 200 - 240V \rightarrow 7 A

3.6 Power consumption

Depending on the voltage range, the maximum power consumption is approx. 1000 W.

3.7 Protection class

IP 21

3.8 Electrical fuses

- Circuit breaker (12): 2 x 10 A T
- Micro-fuse 10 A T in the frequency converter

Technical data

3.9 Material

- Maximum feeding size approx. 10 mm
- Maximum feeding amount 225 ml

3.10 Final fineness

- Dry grinding up to $d_{50} < 20 \mu\text{m}$ (depending on the material)
- Wet grinding up to $d_{50} < 1 \mu\text{m}$ (depending on the material)

4 Installation

4.1 Transport

The device is delivered on a transport pallet with a wooden cover. We recommend using a forklift or pallet truck for transporting the packed device.



DANGER

Do not step under the transport pallet during transport.



WARNING

Improper lifting can lead to personal injury or property damage. The machine is only to be lifted with suitable equipment and by qualified personnel.

The guarantee excludes all claims for damage due to improper transport.

4.2 Unpacking

- Remove the nails that fasten the wooden hood to the transport pallet.
- Lift the hood off the transport pallet.
- The pre-perforated segments can be detached so that the foam parts can be removed more easily.
- Please store the transport packaging so that it can be reused if you need to return the product. Fritsch GmbH accepts no liability for damage caused by improper packaging (packaging that is not from Fritsch).
- Compare the contents of the delivery with your order.



Grinding bowls made of hardened steel may have recesses on the surface caused during production. They do not have an impact on grinding or the grinding results and usually disappear after the first grinding operation.

These recesses on the surface, if present, are within the range of the permissible production tolerances. Complaints relating to such grinding bowls therefore cannot be accepted.

4.3 Setting up



NOTICE

Allow the device to acclimatise for two hours before commissioning. High temperature differences can lead to condensation in the device and damage to the electronics after switching on.

Strong temperature fluctuations can occur during transport or interim storage. Depending on the temperature difference between the installation site and the transport or storage environment, condensation can form inside the device. This can damage the electronics if the devices are switched on too early. Wait for at least two hours after setup before switching on the device.

Installation



DANGER

Do not step under the transport pallet during transport.



CAUTION

The weight of the planetary mono mill is approx. 67 kg!



CAUTION

Crushing hazard!

Always lift with 2 persons.



NOTICE

Never operate PULVERISETTE 6 while it is standing on the transport pallet!

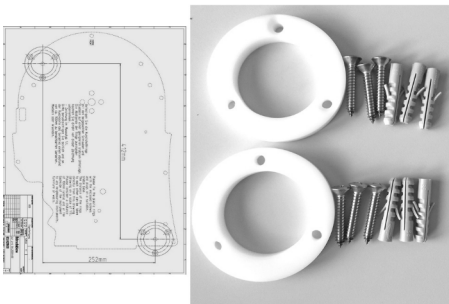

- Lift the mill from the transport pallet with at least 2 persons.
- Place the mill on a flat, stable surface. A fastening set is provided to help stabilise the mill and prevent the mill from shifting during operation. Screw the two rings diagonally into the surface using the drilling template. Place the 2 device feet of the mill into the intended rings.
- Make sure that the planetary mono mill can be easily accessed. There has to be sufficient space to reach the main switch on the back side of the device.
- Keep the air outlet on the side ventilation grate free. Risk of overheating!

4.4 Ambient conditions



WARNING

Mains voltage

- The device may only be operated indoors.
- The surrounding air must not contain any electrically conductive particles.
- Maximum relative humidity 80% for temperatures up to 31 °C, linearly decreasing down to 50% relative humidity at 40 °C.

- The room temperature should be between 5 and 40 °C.
- Altitudes up to 2000 m
- Degree of pollution 2 according to IEC 60664-1:2007.

4.5 Electrical connection



DANGER

Provide short-circuit protection!

Risk of damage due to short-circuits.

- Make sure that the socket is connected to a mains line protected with a residual current circuit breaker.



DANGER

Mains voltage!

Changes to the connection line may only be made by a qualified person.



CAUTION

Ignoring the values on the type plate may result in damage to the electrical and mechanical components.

Before establishing the connection, compare the voltage and current values stated on the type plate with the values of the mains system to be used.

1. Plug the supplied power cord into the port (11) at the back of the device.
2. Then connect the device to the mains using the power cord!



The mains voltage has been set at the factory to that of the specific country. The mains voltage only has to be adjusted if it deviates from the value on the type plate. If adjustment is necessary, proceed as in [Chapter 4.5.1.1 'Adjusting the mains voltage with the rotary switch \(9\)'](#) on page 22 and [Chapter 4.5.1.2 'Adjusting the mains voltage in setup mode'](#) on page 22.



NOTICE

Fritsch mills are speed controlled. The devices are equipped for this with frequency converters. In order to comply with the EMC directive, many measures must be taken to prevent operational transient emissions.

The possible leakage currents resulting from filtering measures can trigger a conventional residual current circuit breaker in the mains line. **This is no defect!**

To prevent this, special residual current circuit breakers, which are adapted for operation with frequency converters, are commercially available.

Operation without a residual current switch is possible, but must be done in accordance with the relevant regulations.

Installation

4.5.1 Adjusting the mains voltage

4.5.1.1 Adjusting the mains voltage with the rotary switch (9)



CAUTION

Only qualified personnel may change the voltage range on the device!



CAUTION

The voltage range may only be adjusted after the mains has been disconnected. Disconnect the device from the mains!



1. ➤ Disconnect the device from the mains!
2. ➤ The rotary switch (9) for adjusting the mains voltage is located on the back side of the device. Rotate this switch to the required voltage.
3. ➤ Connect the device to the mains.

4.5.1.2 Adjusting the mains voltage in setup mode



1. ➤ Press and hold the STOP button on the front of the control panel.

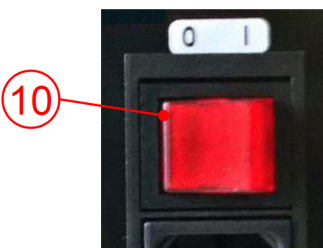

2. ➤ Switch on the device with the main switch (10) on the back side of the device, and release the STOP button.
3. ➤ If POWER SUPPLY is flashing, the device is in setup mode. If POWER SUPPLY is not flashing, repeat the procedure.

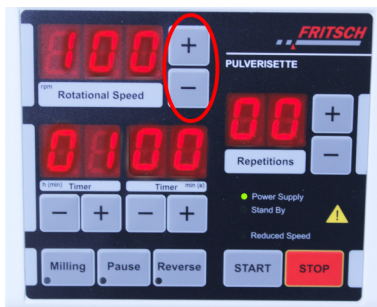

4. ROTATIONAL SPEED control panel area

Use the +/- ROTATIONAL SPEED buttons to adjust the level of the mains voltage (90-260 V) to the existing mains system.



5. To save and end setup mode, press the STOP button.

4.6 Setting device specifications



NOTICE

"P6" must always be displayed in the REPETITIONS field. The Fritsch company will give no guarantee for damage resulting from disabling of the imbalance switch.

5 Initial start-up

Perform initial start-up only after all work as described in [Chapter 4 'Installation'](#) on page 19 has been carried out.

5.1 Switching on

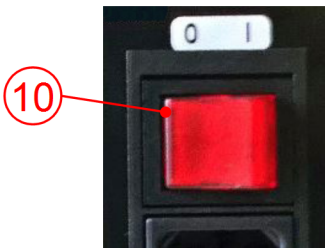

- The device must be connected to the power supply if this has not been done already.
- Switch on the device with the main switch (10) on the back side of the device.
- The POWER SUPPLY lamp lights up.

5.2 Function check



CAUTION

Only perform the function check at a speed of 100 1/min. The counterweight must be positioned completely inwards to prevent too great an imbalance.

- Open the hood (3).
- Take out the grinding bowl tensioning device (Safe-Lock) and transport securing device (wooden block). No loose parts may remain inside the device.
- Position the counterweight completely inwards. (See [Chapter 6.6 'Mass balance'](#) on page 36)
- Close the hood (3).
- Set the speed to 100 1/min. (See [Chapter 6.8.1 'Setting the speed'](#) on page 37)
- Press START on the control panel.
- The hood (3) is locked and the mill starts up at the preselected speed.

6 Using the device



DANGER

Before starting the machine, make sure that the grinding bowl has been tensioned correctly and that there are no loose parts inside the device. There is a risk of loose grinding bowls or parts being projected. Failure to observe this will render void the guarantee, and releases us from liability for any resulting damage to the device or personal injury.



NOTICE

During grinding, high temperatures and high pressure may appear in the grinding bowl.

In encased grinding bowls, the inserts are glued into the casing with a two-component construction adhesive.

The adhesive is resistant to temperatures up to approx. 140 °C. Above 140 °C, the adhesive will liquefy. That can cause irreparable damage to the insert. The grinding bowl will definitely be rendered unusable.



The device requires a start-up phase at the beginning in order to reach maximum performance. A well-filled and heavy grinding set may initially operate at a lower speed than after running for approximately 1 - 2 hours.

6.1 Choice of grinding bowls and grinding balls



CAUTION

If the grinding elements used are not genuine accessories, we assume no guarantee and exclude all liability for damage to the device or for personal injury.



CAUTION

The grinding element is subject to normal wear when used. Before every grinding operation, check the wall thickness of the grinding bowls. In the event of severe wear, replace the grinding bowl. If this is not done, the prevailing high centrifugal forces during grinding may cause the grinding balls to penetrate the bowl's wall and damage the mill. Failure to observe this will render void the guarantee and release us from liability for any resulting damage to the device or personal injury.

Using the device



NOTICE

Each grinding process means wear to the grinding element. Therefore, please pay attention to what components the material of the grinding element contains and whether these could react with the sample. Such reactions may have consequences. A simple reaction with minor consequences may be, for example, the grinding of samples containing sulphur in the steel bowl, which contains iron. The iron released by abrasion can combine with sulphur and react to form iron sulphide. This can lead to black deposits on your grinding set.

The hardness and density (specific weight) of the grinding bowl and grinding balls used have to be greater than that of the material used to prevent excessive wear by abrasion.

Material (bowl and balls)	Main components of the material	Density in g/cm ³ High density means high impact energy!	Abrasion resistance	Use for grinding stock
Agate	(99.9% SiO ₂)	2.65	Good	Soft to medium-hard samples
Silicon nitride	(90% Si ₃ N ₄)	3.25	Extremely good	Abrasive samples, metal-free grinding
Sintered corundum	(99.7% Al ₂ O ₃)	3.9	Fairly good	Medium-hard, fibrous samples
Zirconium oxide	(96.2% ZrO ₂)	5.7	Very good	Fibrous, abrasive samples
Hardened, stainless steel	(16.0 - 18.0% Cr)	7.7	Fairly good	Medium-hard, brittle samples
Tungsten carbide	(93% WC + 6% Co)	14.9	Very good	Hard, abrasive samples

The grinding bowls and grinding balls made of zirconium oxide are resistant to acids - apart from hydrofluoric acid.

Normally choose a grinding bowl and grinding balls that are made of the same material.

Exception: Tungsten carbide balls (<20 mm) may be temporarily (a few minutes) combined with grinding bowls made of hardened steel.

6.1.1 Size of the grinding balls

Type of feed material	Suitable ball diameter
Coarse feed size 5 - 10 mm	30 mm or 40 mm
Average feed size of < 5 mm	20 mm, 15 mm or 10 mm
Fine material < 0.5 mm	10 mm or smaller

Type of feed material	Suitable ball diameter
Homogenisation of dry or liquid samples	20 mm or smaller
Homogenisation of viscous samples	20 mm

These are reference values: The size of bowls and grinding balls may need to be determined through experimentation.

NOTICE

It is not advisable to mix balls of different diameters. If balls with different diameters are used, increased wear and damage to the grinding elements is to be expected.

NOTICE

Balls with a diameter of 40 mm are rarely used for grinding, because this ball size can cause damage to the grinding bowl fast if the grinding duration is too long. Only use grinding balls of this diameter for brief grinding durations.

Using the device

6.1.2 Recommended number of balls per grinding bowl (independent of the material quantity)

A higher number of balls will reduce the grinding time and the grinding result will have a smaller particle size distribution.

Ball diameter (mm)	Grinding bowl volume (ml)	80	250	500
5	Number of balls (pcs)	250	1200	2000
10	Number of balls (pcs)	25	50	100
15	Number of balls (pcs)	10	45	70
20	Number of balls (pcs)	5	15	25
30	Number of balls (pcs)	-	6	8
40	Number of balls (pcs)	-	-	4

Balls Ø 3mm and smaller

Material	Grinding bowl volume (ml)	80	250	500
Zirconium oxide	Weight of balls (gram)	100	400	800
Hardened, stainless steel	Weight of balls (gram)	150	500	1100
Tungsten carbide	Weight of balls (gram)	300	1000	2100

These are reference figures: The number of balls may need to be determined through experimentation. The minimum number of balls advised is binding.



CAUTION

When grinding with a ball size of Ø 30 mm or Ø 40 mm, do not let the device run unsupervised. The vibrations may lead to shifting.

6.1.3 Average calculated weight of a ball

Ball diameter in mm		5	10	15	20	30	40
Material	Density in g/cm ³	Calculated weight of a ball in g					
Agate	2,65	0,17	1,39	4,68	11,1	37,46	88,8
Silicon nitride	3,25	0,21	1,7	5,74	13,61	45,94	108,91
Sintered corundum	3,9	0,25	2,04	6,89	16,33	55,13	130,69
Zirconium oxide	5,7	0,37	2,99	10,07	23,88	80,58	191,01
Hardened, stain-less steel	7,7	0,50	4,03	13,60	32,25	108,86	258,03
Tungsten carbide	14,9	0,97	7,8	26,33	62,41	210,64	499,3

To determine the weight of the balls to be used, the "calculated weight of a ball" is multiplied by the "number" of balls required.

Example: A 250 ml agate bowl is to be filled with 1250 x 5 mm agate balls.

Calculation: $0.17 \text{ g} * 1250 \text{ pcs} \approx 212.5 \text{ g}$

212.5 g of grinding balls can be weighed and inserted in the grinding bowl, thus avoiding the time required for counting the balls.

6.2 Filling quantities of grinding bowls



CAUTION

For grindings with large balls with a diameter of >10 mm, at least half of the maximum sample quantity must be inserted. If the suspension is highly fluid or the material quantity is too small, the balls will not have any resistance and the balls and the grinding bowl could be damaged. The result is the same as if it had been filled with no grinding stock.



NOTICE

Never operate the mill without grinding stock! This can lead to grinding balls and grinding bowls getting damaged.



NOTICE

If the minimum filling quantity is fallen short of, increased wear due to abrasion is to be expected. This can cause irreparable damage to the mill components.

Using the device



NOTICE

The filled in volume can increase during the grinding. Check the volume after a brief grinding time.

Grinding bowl	Min. sample volumes	Max. sample volumes
500 ml	80 ml	225 ml
250 ml	30 ml	125 ml
80 ml	10 ml	30 ml

6.3 Filling the grinding bowl



CAUTION

Do not fill in any dry ice or liquid nitrogen in the grinding bowls!

Adding dry ice or liquid nitrogen into the grinding bowls can lead to a sudden increase in volume with a high static pressure. This can result in an explosion of the grinding bowls.

Do not fail to comply with the following sequence:

1. Place the grinding balls in the empty bowl.
2. Fill grinding stock onto the balls.



NOTICE

Make sure the sealing surface is clean and the seal is not damaged.

3. Place the lid on the grinding bowl.

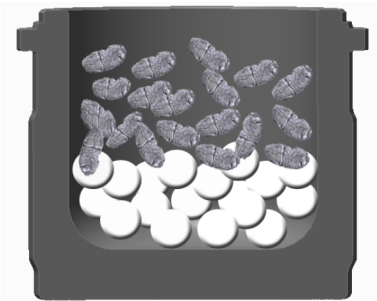

6.4 Factors with an impact on grinding

6.4.1 Running time (grinding duration)

To reduce the grinding time, you can use a grinding bowl and grinding balls with a higher density, and thus a higher impact energy.

6.4.2 Speed

Higher speeds shorten the grinding time and increase the percentage of fine particles.

Lower speeds increase the grinding time and lower the temperature, which can lead to fewer pauses. This means that the overall working time may remain the same. The wear is increased in this case though.



Fritsch recommends however to use the maximum speed and to plan for enough pauses so that the wear is minimised.



For thermally sensitive materials, the optimal rotational speed needs to be determined through experimentation.

6.4.3 Reverse mode

- Useful for mechanical alloying
- Improvement of the homogeneity of the sample

6.4.4 Number and size of the balls



NOTICE

It is not recommended to mix balls with different diameters and/or materials (bowls and balls must always be of identical material!). If balls with different diameters are used, increased wear and damage to the grinding elements is to be expected.



You can find the recommended number and size of balls in → Chapter 6.1 'Choice of grinding bowls and grinding balls' on page 25.

Larger balls are used for pre-crushing. (See → Chapter 6.1.2 'Recommended number of balls per grinding bowl (independent of the material quantity)' on page 28).

To increase the proportion of fine particles, the large balls need to be replaced by smaller ball sizes during the course of the grinding process.

6.4.5 Weight of the balls (type of material)

A higher mass (specific weight) of the grinding balls accelerates grinding. (see table in → Chapter 6.1 'Choice of grinding bowls and grinding balls' on page 25).

Using the device

6.4.6 Dry grinding



DANGER

Dust explosion!

There is a risk of spontaneous combustion especially for very fine metal oxides and a thus resulting dust explosion. Mind the external temperature and the pressure that can develop in the grinding bowl during the dry grinding.



NOTICE

Dry grindings need to be checked in briefer intervals. Longer dry grindings, without pauses and checks, can cause the grinding set to gum up and to become damaged. In particular with agate, the grinding bowl and grinding balls can become damaged after a short grinding time.

At a particle size of less than 20 µm, the surface forces prevail. The grinding stock begins to stick.

Additional dry comminution can be achieved by adding surface-active substances to the material to be ground.

Examples (maximum amount to be added in mass %)

- Stearic acid 2-3 %
- Aerosil (fine-particle silicic acid) 0.5 - 2 %
- Quartz sand ~ 2 %
- Glass powder ~ 2 %
- Glycol (Ethylene glycol) ~ 0.1 - 0.5 % (Δ 5 - 25 droplets)
- Triethanolamine ~ 0.1 - 0.5 %

6.4.7 Wet grinding (grinding in a suspension)



DANGER

Explosion hazard! Ignition hazard!

The device is not explosion-protected. If flammable liquids are used, make sure that the heat developing in the grinding bowl (outer wall max. 80 °C) does not reach the solvent's boiling point. Program appropriate cooling phases. If the vapour pressure is too high, vapours may escape and ignite. If it can be avoided, we recommend using non-flammable liquids or liquids with a high boiling point. The boiling point should be above 100 °C.



Make sure that the viscosity is sufficient during wet grinding. Especially if the grinding time is longer, a readjustment can be necessary.

When changing over to grinding in suspension, you can add liquid auxiliary agents with a high boiling point and low vapour pressure, e.g. water, white spirit (boiling point 100 - 140 °C) or high-boiling alcohols (e.g. glycerine).

We recommend that you only use so much liquid that the suspension, including the balls, has the same consistency as engine oil. With this viscosity the best results can be achieved in most cases.

6.5 Clamping the grinding bowls

6.5.1 Clamping with the "Safe-Lock" (5) tensioning device



Fritsch GmbH confirms that every Safe-Lock clamping system has been manufactured and tested to our internal quality standards. Fritsch GmbH measures the clamping force of each individual Safe-Lock clamping system. The clamping force must be in the range of 11.2 - 11.3 kN +/- 0.2kN.

Click on the following link to watch a step-by-step video guide on how to use the Safe-Lock clamping device. ➔ [Click here.](#)

Prior to every grinding, carry out the following checks before clamping the grinding bowls:

- Has the rubber disk (6.1) been inserted into the grinding bowl holder? The rough side should be facing upwards!
- Check the rubber disk in the grinding bowl holder for damage: Replace the rubber disk if it has been pressed flat!
- The Teflon flat seal (for the sealing between lid and bowl) may not be damaged or soiled. Replace heavily deformed Teflon flat seals.
- The surfaces of the lids and bowls on which the Teflon flat seals lie must be clean!
- Check the rubber disk of the pressure piece for damage! Replace rubber disks that have been pressed flat and are protruding laterally from the pressure piece.
- Make sure that the thread on the Safe-Lock is not soiled and not damaged. Both can lead to a premature actuation of the torque spanner and thus preventing the required final clamping force from being reached.

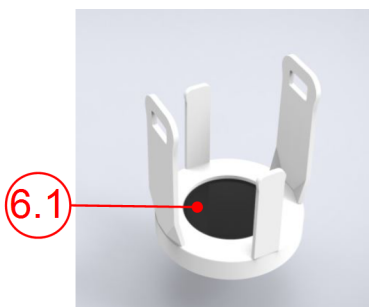

Clamping

1. ➔ Position the bracket (a) of the clamping lever vertically!

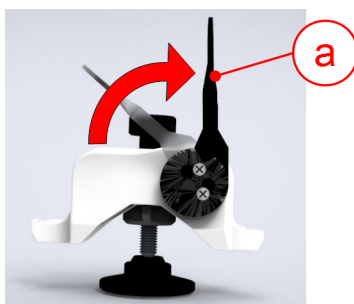

Using the device

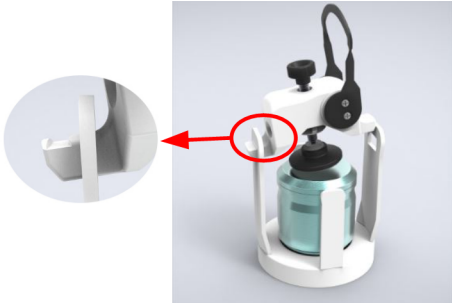

2. ➤ Hang the longer projection of the Safe-Lock clamping device onto the cut-out of the grinding bowl holder.

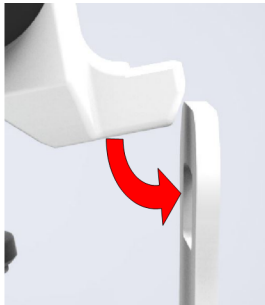

3. ➤ Hang the short projection of the Safe-Lock clamping device into the other side.

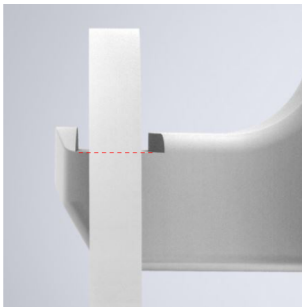

4. ➤ Push the Safe-Lock clamping device so that the cut-out of the grinding bowl holder sits centrally in the U-shaped cut-out of the longer projection.

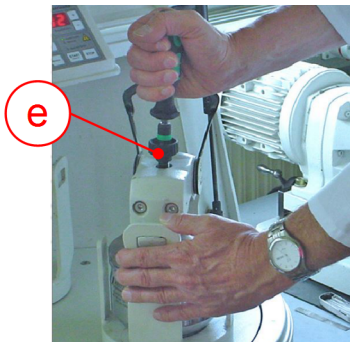

5. ➤ Pre-tension the setting screw (e) manually, then place the provided torque spanner on the setting screw (e) and turn until it clicks. (2.6 Nm)



Make sure that you do not turn the torque spanner too fast. This could prevent the correct final clamping force from being reached.



6. → Then press the clamping lever downwards.
7. → Wait a few seconds. Release the Safe-Lock again and turn the setting screw (e) again using the torque spanner until it clicks.
8. → Press the clamping lever downwards again. The Safe-Lock system is now tensioned!



DANGER

After several minutes of grinding and in the cooling-down phases, check that the tensioning device is firmly connected.



If the Safe-Lock system is correctly tensioned, the clamping lever is automatically pulled downwards by the eccentric when horizontal.

6.5.2 Clamping the 80 ml grinding bowls

There are two ways of clamping an 80 ml grinding bowl:

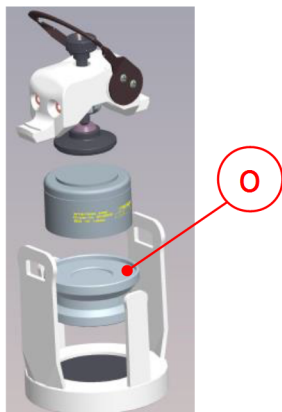

1. → Place the reducer (o) (order no. 90.1120.09) into the grinding bowl holder and position the 80ml grinding bowl on it and fasten with the Safe-Lock tensioning device.



2. → Alternatively, clamp two 80 ml grinding bowls on top of one another.



Tensioning with the Safe-Lock system proceeds as described in → Chapter 6.5.1 'Clamping with the "Safe-Lock" (5) tensioning device' on page 33.

Using the device

6.6 Mass balance

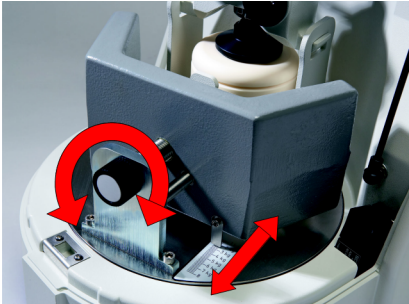

Click on the following link to watch a step-by-step video guide on how to adjust the counterweight. ➔ [Click here](#).

The counterweight (6) has to be positioned according to the scale in order to offset the imbalance and thus prevent the mill from shifting.

The weight indicated on the scale is the weight of the filled grinding bowl with the lid on.



NOTICE

It may be necessary to readjust the mass balance if the bowls are heavy or the speeds are high.



NOTICE

Extra weights, like "GTM" and "additional clamping system", have to be balanced as well.

6.7 Grinding duration



CAUTION

Burn hazard!

Grinding bowls can get very hot after long grinding durations. Wear protective gloves for removal after grinding or during the grinding breaks.

Depending on the application, the grinding time should be adapted to the development of heat in the bowls. The internal bowl temperature can be much higher than the outside wall temperature. A guide value for the ratio of grinding time to pause time is 1 to 3. This means that if the grinding time is one minute, you must allow for a 3-minute pause time. If liquids are used, the guide value is shifted towards pause times. Here the guide value goes in the direction of one minute grinding time and 10 minutes pause time!



CAUTION

The outer wall of the grinding bowl must not exceed 80 °C.

The longest grinding time is therefore based on the maximum bowl temperature. The grinding time at which this temperature is not exceeded depends very much on the material, the balls and the speed of rotation and must therefore be determined by the user through experimentation.



To what extent the heating up of the material to be ground needs to be observed naturally depends on the corresponding sample in each individual case. Note → a longer duration may also require a long pause time for cooling down.

To reduce the grinding time, you can use a grinding bowl and grinding balls with a higher density, and thus a higher impact energy.

The mill can also run for several hours during low-speed operations for mixing and homogenisation, while monitoring the temperature.

Operation with an external time switch is not possible.

6.8 Settings on the control panel

6.8.1 Setting the speed



- Switch on the main switch (10) on the back side of the device (I).
- The green POWER SUPPLY ready status indicator lights up on the control panel.

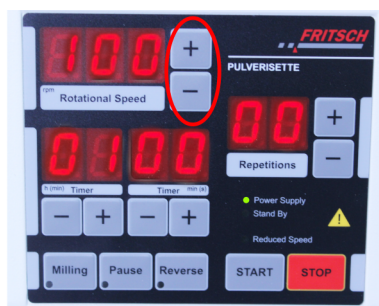

ROTATIONAL SPEED control panel area

Press and hold the + or - button.

The speed can be selected in steps of 10 between 100 and 650 1/min.

The actual speed is displayed during operation. The nominal speed is briefly displayed when the + or - button is pressed.

6.8.2 Setting the running time

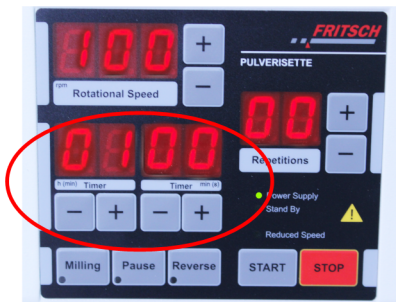

TIMER control panel area

Setting the grinding time

1. ➤ Press the "MILLING" button.
 - ➔ The "MILLING" button lights up
2. ➤ Press the + or - buttons to set the running time in hours (0–99) and minutes (0–59) or in minutes (0–59 and seconds (0–59).

Set the pause time

1. ➤ Press the "PAUSE" button.
 - ➔ The "PAUSE" button lights up.
2. ➤ Press the + or - buttons to set the pause time in hours (0–99) and minutes (0–59) or in minutes (0–59 and seconds (0–59).

If no pause time is required, set the pause time to 0.



- If the combination minutes/seconds is set in setup mode instead of hours/minutes (see ➔ Chapter 6.8.2.1 'Setting time units' on page 38), the numbers at **h** indicate the minutes and at **min**, the seconds!

The **factory setting** of the time unit is minutes and seconds. (Display: 1)

- The remaining running times and the pause times are displayed during operation.
- Operation with an external time switch is not possible.
- For running times see ➔ Chapter 6.4.1 'Running time (grinding duration)' on page 30.
- Interrupt grinding by pressing the STOP button. Continue grinding by pressing the START button. This takes into account the previous grinding duration and the number of repetitions.

6.8.2.1 Setting time units



1. ➤ When the device has been switched off, press and hold the STOP button on the front control panel.

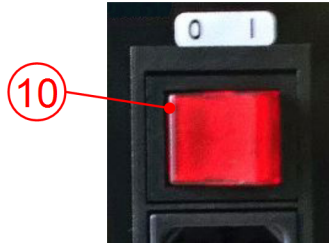

2. → Switch on the device with the main switch (10) on the back side of the device.
3. → If POWER SUPPLY is flashing, the device is in setup mode. If POWER SUPPLY is not flashing, repeat the procedure.



4. → To perform changes, press the right "+" button (y) in the TIMER field:
Time unit, hours and minutes → Display: -
Time unit, minutes and seconds → Display: 1 (factory setting)
5. → To save and end setup mode, press the STOP button.

6.9 Repetition of grinding / pause cycles

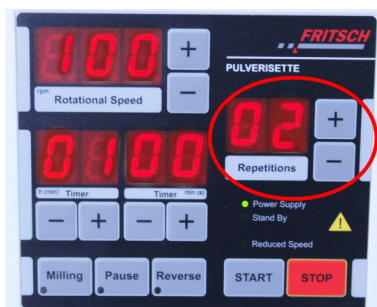

REPETITIONS control panel area

Press + or - button; select the number of repetitions (0..99). The number of remaining cycles is displayed during operation.

6.10 Reverse mode



→ Press the REVERSE button. The button lights up.

After the selected running time expires, the mill will change its direction of rotation. For this, REPETITIONS has to indicate at least 1.

"Reverse" is selected when mixing dry samples, for example.

6.11 Conducting a grinding operation



- After all the preparations described in [Chapter 6.1 'Choice of grinding bowls and grinding balls'](#) on page 25 to [Chapter 6.10 'Reverse mode'](#) on page 39 have been carried out, close the hood (3).
- Press the START button on the control panel.
- The hood is locked and the mill starts up.
- The mill turns at the set speed (nominal speed). If the load is too great, for example due to heavy grinding bowls, the speed is reduced (actual speed) so that the machine is not overloaded.
→ The "REDUCED SPEED" lamp is lit!



If the mill does not start, see [Chapter 10 'Repairs'](#) on page 63



While in operation, the hood (3) remains locked, even during pause times, and the fan cools the interior.

6.11.1 Overload



The device requires a start-up phase at the beginning in order to reach maximum performance. A well-filled and heavy grinding set may initially operate at a lower speed than after running for approximately 1 - 2 hours.



Since a static mass (grinding bowl, grinding bowl holder and planetary disk) and the dynamic mass (grinding balls and sample material) counteract each other, heavy grinding bowls and balls and maximum sample quantities can result in a load that causes a reduced rotational speed!

If the mill is overloaded, the speed is reduced and the REDUCED SPEED light flashes.

The mill switches off if the overload continues for too long; see [Chapter 10.1 'Checklist for troubleshooting'](#) on page 63.

6.11.2 Switching off

- Press STOP on the control panel.
- When the drive comes to a standstill, the hood is unlocked and can be opened.
- If the device is not in operation for a long time, switch off the main switch on the back side.

6.12 Cooling the grinding bowl



 **WARNING**

Burn hazard!

Grinding bowls can get very hot after long grinding durations. Wear protective gloves for removal after grinding or during the grinding breaks.

- When the hood is open (3), or
- In the programmed pause times with closed (locked) hood and the fan running.

6.13 Stand-by

If the mill is not in operation and the hood (3) is open, it switches to the energy-saving stand-by mode after one hour. The STAND-BY lamp lights.

The stand-by function is not possible when the hood is closed.

7 Accessories

7.1 Additional clamping system for grinding harmful substances or in a gas atmosphere.

The additional clamping system is used to transport a grinding bowl filled with inert gas or harmful substances from a glove box to the planetary mill and back again. This ensures that no harmful substances can be inhaled.

There are two ways of gassing the grinding bowls:

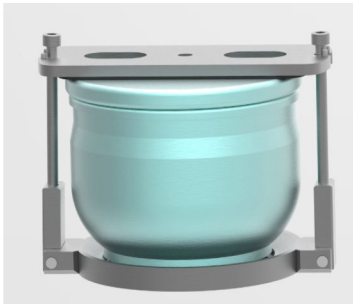

1. → Grinding bowls with standard lids have to be filled in a glove box with an inert gas atmosphere and closed using the additional clamping system. Using this procedure you can even grind hazardous substances!

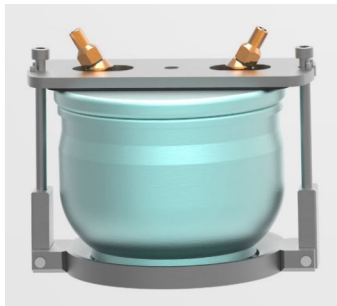

2. → Grinding bowls with gassing lids can also be closed and gassed outside the device using the additional clamping system.

7.1.1 Locking the additional clamping system into place

1. → When using the additional clamping system, exchange the white Teflon seal with the fitting, enclosed black Viton seal for sealing the grinding bowl.
2. → Place the grinding bowl in the grinding bowl adapter (a) of the additional clamping system.

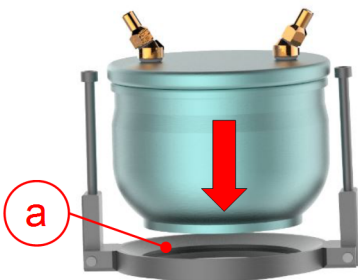

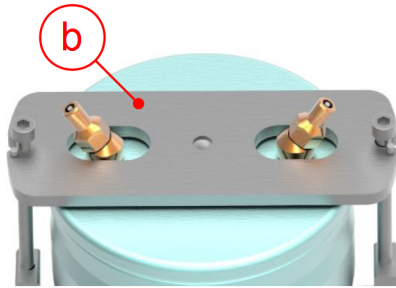

3. → Position the pressure plate (b) with the rubber disk on the bowl as shown in the picture.

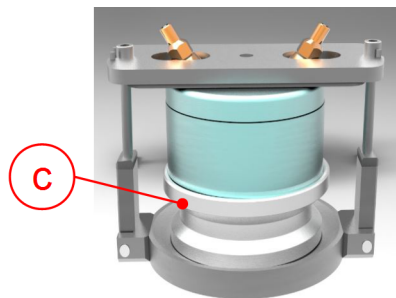

4. →



NOTICE

When using grinding bowls with a volume of 80 ml in the additional clamping system, the adapter piece (c) (90.1120.09) provided in the accessories must be used.

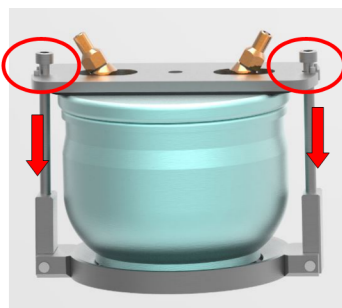

5. → Then tighten both socket-head screws (d) shown in the diagram equally with a hex key and thereby clamp the pressure plate tightly. Ensure that the pressure plate is lying evenly on the bowl lid.

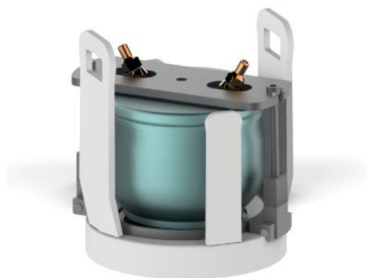

6. → Place the additional clamping system with clamped bowl in the grinding bowl holder.

Accessories



7. The pressure piece has to be removed in order to use the Safe-Lock system for clamping.

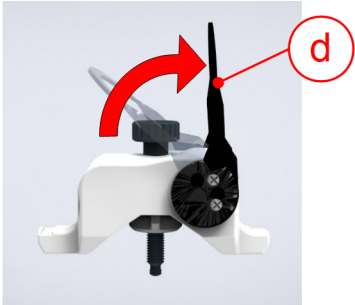

8. Position the bracket (d) vertically!

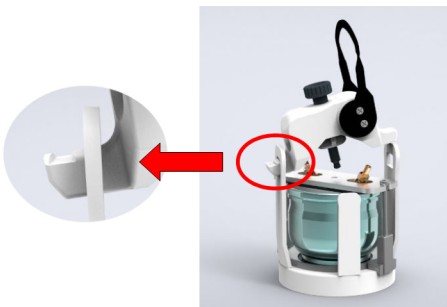

9. Hang the longer projection of the Safe-Lock clamping device into one side of the mounting of the grinding bowl holder.

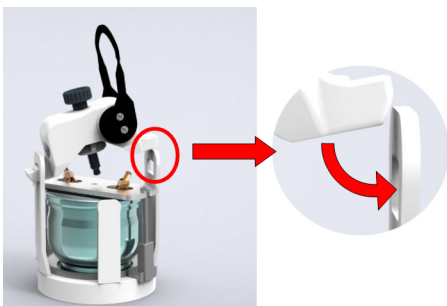

10. Hang the short projection of the Safe-Lock clamping device into the other side.



- 11.** Ensure that the journal of the threaded spindle (where the pressure piece was previously affixed) is sitting in the bore hole provided in the pressure plate (b).

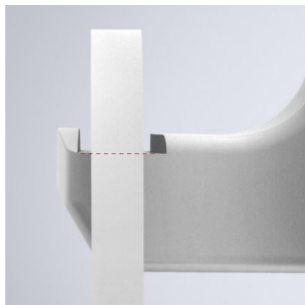

- 12.** Push the Safe-Lock clamping device so that the mounting of the grinding bowl holder sits centrally in the U-shaped cut-out of the longer projection.

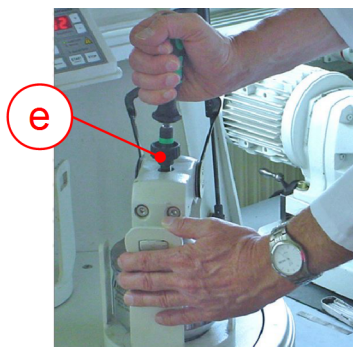

- 13.** Pre-tension the setting screw (e) manually, and screw it tight using the provided torque spanner. Place the torque spanner provided on the setting screw (b) and turn until it clicks. (2.6 Nm)



Make sure that you do not turn the torque spanner too fast. This could prevent the correct final clamping force from being reached.



- 14.** Then press the clamping lever downwards.
15. Wait a few seconds. Release the Safe-Lock again and turn the setting screw (e) again using the torque spanner until it clicks.
16. Press the clamping lever downwards again.
17. Re-tighten the screws in the additional clamping system with a hex key.



DANGER

The additional clamping system may be loosened due to the clamping of the Safe-Lock using the clamping lever. Check the screw connections of the additional clamping system and the Safe-Lock tensioning device for tight fit before starting grinding. Failure to observe this instruction may lead to serious material damage or personal injury.



DANGER

After several minutes of grinding and in the cooling-down phases, check that the tensioning device is firmly connected.



If the Safe-Lock system is correctly tensioned, the clamping lever is automatically pulled downwards by the eccentric when horizontal.

7.2 Grinding in inert gas with gassing lid



NOTICE

Observe imbalance offsetting! (See → Chapter 6.6 'Mass balance' on page 36).



NOTICE

Before every grinding operation, check the valves of the gassing lid ensuring that they are clean and properly secured. See chapter → Chapter 7.2.4 'Cleaning the valves' on page 48.



We carry out a worker water bath test on all gassing lids. The part to be tested is sealed, a pressure of 5.5 bar is applied and it is immersed in a water bath. If there is a leak, bubbles will develop. The air bubbles that develop within a specific interval are evaluated by the worker/tester.

Only gassing lids with a leak rate of $< 10^{-4}$ [mbar l/s] are approved.

When grinding in inert gas, the same conditions apply regarding clamping and composition of grinding set and balls, as apply for standard grinding.

Two valves are screwed onto the gassing lid through which you can feed in inert gas (e.g. nitrogen) before switching on the mill. A Viton flat seal is used instead of a Teflon one.

7.2.1 Preparation for gassing

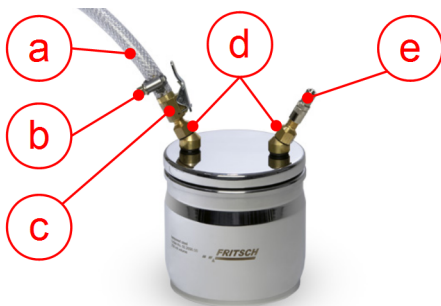

- a Gassing hose
- b Hose clamp
- c Coupling
- d Valves
- e Ventilation attachment

- Fill the grinding bowl with grinding balls and grinding stock. (See → Chapter 6.3 'Filling the grinding bowl' on page 30)
- Attach the Viton seal and lid.
- Insert the grinding bowl into the grinding bowl holder (8).
- Clamp the grinding bowl in the device (See → Chapter 6.5 'Clamping the grinding bowls' on page 33)

Using the additional clamping system, the following steps can also be completed in the glove box and subsequently clamped in the Planetary mono mill:

- Connect the gassing hose (a) to the inert gas supply using the provided hose clamp (b).
- Screw the ventilation attachment (e) onto one of the two valves (d).
- Place the coupling (c) of the gassing hose on the free valve. When doing so, press the lever of the coupling and push the coupling along the neck of the valve until it goes no further. Release the lever.



Using the additional clamping system, the closed grinding bowl can also be tensioned and gassed outside of the device. (See → Chapter 7.1.1 'Locking the additional clamping system into place' on page 42)

7.2.2 Gassing

- Slowly open the inert gas supply.
- Press a thin object (e.g. hex key) onto the top of the ventilation attachment (e) so that the air can escape from the grinding bowl.
- The inert gas now purges the air from the grinding bowl.
- The duration of purging has to be determined through experimentation. It depends on grinding bowl size, filling, and gas supply, among other factors.
- To end purging, close the inert gas supply and release the ventilation attachment.
- Screw off the ventilation attachment.
- Remove the gassing hose. To do so, press the lever.



CAUTION

Only switch on the device when both coupling and ventilation attachment have been removed.

Overpressure may occur during grinding!

7.2.3 Ventilate after grinding



CAUTION

Always let the bowl cool down before ventilation. Hot gases and sample material may escape from the bowl during pressure equalisation, leading to serious burns.

→ Use protective gloves when ventilating!

- When the bowl has cooled down, remove the additional clamping system with bowl from the device.
- Screw the ventilation attachment onto the valve. Each valve can be used for aerating or ventilating.
- For pressure equalisation (of the overpressure occurring because of grinding), carefully press on the ventilation attachment with a thin object (e.g. hex key).
- Only now should you release the additional clamping system (5)!

7.2.4 Cleaning the valves

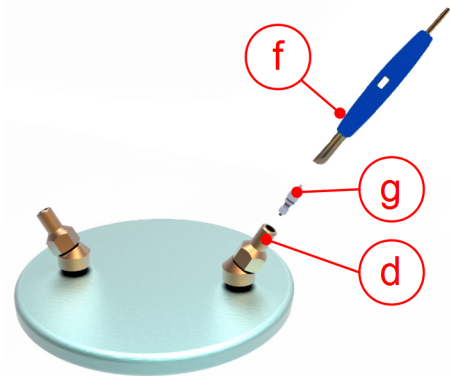

- f Valve screwdriver
- g Valve insert (84.6360.00)
- d Valves

Both valves (d) should be cleaned after every grinding!

- Insert the thin end of the valve screwdriver (f) from above into the valve (d) and turn anti-clockwise.
- Screw out the valve insert (g).
- Depending on the soiling, clean the valve insert (g) with compressed air, or place it in a small glass container filled with alcohol and clean in an ultrasonic cleaner (LABORETTE 17) and then dry carefully.
- After the two valve inserts have been removed, the two valve holders can be cleaned with compressed air from above the lid.

7.2.5 Installing valve inserts

- Insert the valve insert (g) into the valve (d) with the spring pointing upwards.
- With the valve screwdriver (f), screw the valve insert clockwise.

The following gassing lids for the grinding sets are available, each with two valves and a soft sealing ring:

Material	Order number
Hardmetal tungsten carbide 80 ml	50.8880.00
Hardmetal tungsten carbide 250 ml	50.8600.00
Hardened, stainless steel 80 ml	50.8700.00
Hardened, stainless steel 250 ml	50.8500.00
Hardened, stainless steel 500 ml	50.8400.00
Agate 80 ml	50.8100.00
Agate 250 ml	50.8100.00
Agate 500 ml	50.8010.00
Zirconium oxide 80 ml	50.8840.00
Zirconium oxide 250 ml	50.8950.00
Zirconium oxide 500 ml	50.9100.00
Silicon nitride 250 ml	50.8900.00
Silicon nitride 500 ml	50.9150.00

**NOTICE**

The soft black sealing rings made of "Viton" can endure temperatures of approx. 200 °C.

The valves (d) can endure temperatures of approx. 180 °C for one hour at most.

**NOTICE**

The grinding parts made of agate are only designed for temperatures of up to 100 °C. After this point, they need to be slowly and carefully cooled down.

7.3 EASY GTM Gas Pressure and Temperature Measuring System

The EASY GTM gas pressure and temperature measuring system is used to control the grinding process and for mechanical alloying.

**NOTICE**

If grinding balls with a diameter of 1 mm or smaller are used, there is a risk of the through holes in the lid getting clogged, which could falsify the pressure and temperature measurement. If these ball sizes are used nevertheless, the grinding process must not be carried out unobserved. The intermediate lid should be checked at regular intervals during the grinding process. When the MillControl software is used, the pressure and temperature are displayed. If the pressure remains constant, the cause of this may be a clogged intermediate lid.

7.3.1 Case contents and system design

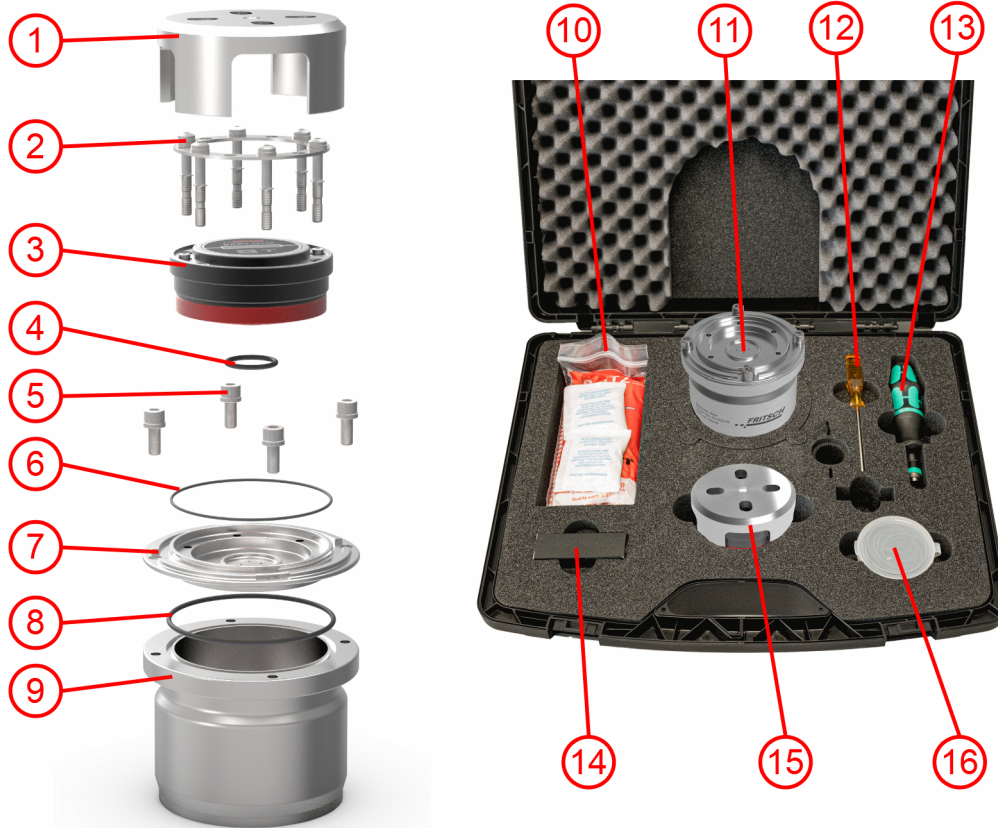

- 1 support ring
- 2 Lock ring with the 6 hexagon screws
- 3 Measuring/Transmission unit
- 4 O-ring 21 x 2.5 mm
- 5 4 hexagon screws with retaining rings
- 6 O-ring 76 x 1.5 mm
- 7 Filter lid
- 8 O-ring 78 x 2.5 mm

- 9 Bowl
- 10 Cleaner
- 11 Bowl with filter lid
- 12 Screwdriver
- 13 Torque spanner
- 14 USB stick with software and documentation
- 15 Support ring with measuring/transmission unit
- 16 O-rings and hexagonal bit

7.3.2 Inserting / changing the battery

When inserting it for the first time and during subsequent replacement of the battery, proceed as follows:

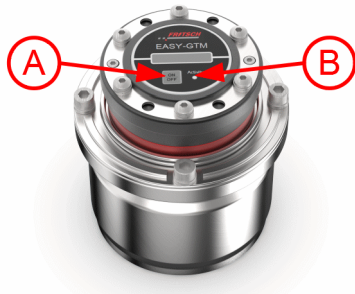

1. → If not already done, switch off the radio system using the button (A). The LED (B) goes out.



2. → Loosen the six hexagon screws with the hexagon screwdriver. The lock ring (2) with the 6 hexagon screws can now be removed. (See → Chapter 7.3.6 'Cleaning the EASY GTM system' on page 57)



3. → **Carefully** lift the measuring/transmission unit (3) off the bowl (9).



4. → Undo the two screws (D) of the battery compartment using a hexagon offset screwdriver, size 2.5 mm.

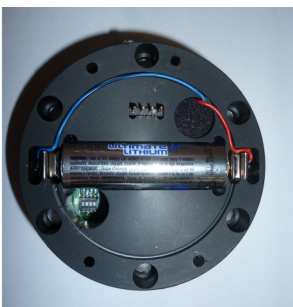

5. → Lift off the battery compartment lid and place it to the side. The battery compartment can be seen.



NOTICE

Please note that the battery fits exactly in place and may need to be pushed in using a certain amount of force.

The service life of the battery depends on the frequency of the wireless protocols (see configuration) and essentially on the temperature inside the grinding bowl.

Also pay attention to the battery's charge level. If the battery's capacity falls below 10 %, it should be replaced immediately.

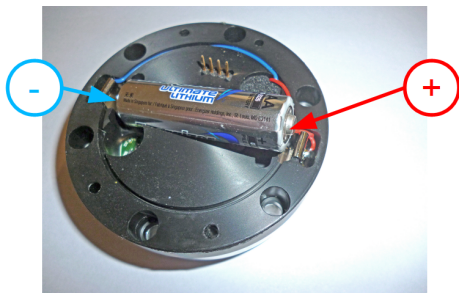

6. → Remove the old battery and insert the new battery. Battery type: 1.5 V / AA Lithium



Pay attention to the polarity when inserting the battery!

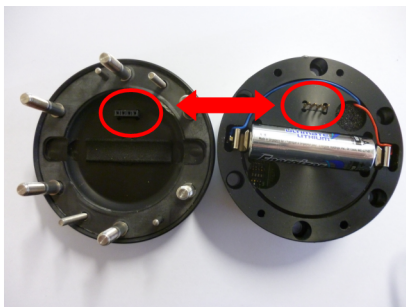

7. → Ensure that the plug contacts are in the correct position when closing the battery compartment!

7.3.3 Configuration of transmitter ID and data transmission frequency

The measuring/transmission unit (3) is equipped with four configuration switches for setting the transmitter ID and data transmission frequency.

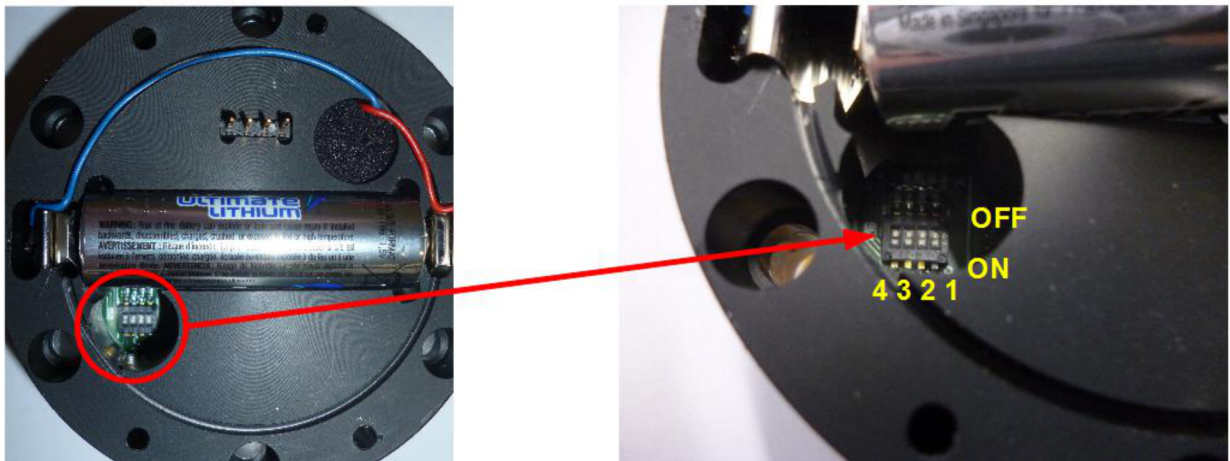

The switches illustrated are all in the **OFF** position (actuator cams set to OFF).

7.3.3.1 Adjustment options of the transmitter detection

In the delivery condition all switches are set to OFF. It is recognised that, in this case, bowl 1 and the transmission frequency of 1 second are the set values. The bowl with ID 1 must then also be inserted in the indicated position 1 of the mill. Similarly the EGTM system with ID 2 must be positioned in position 2 of the mill.

ID	Switch 1	Switch 2
Transmitter no. 1	OFF	OFF
Transmitter no. 2	ON	OFF



If other switch settings are set, the EGTM systems will not be recognised. Ensure that the settings shown in the table are used for your systems and that they are used in the correct position in the mill.

7.3.3.2 Transmission frequency setting options

Transmission every	Switch 3	Switch 4
1 second	OFF	OFF
½ second	ON	OFF

Transmission every	Switch 3	Switch 4
¼ second	OFF	ON
automatic	ON	ON

1-second transmission is the default value.

For automatic transmission, the 1 / ½ / ¼ second transmission frequency is switched over in the event of fast changes in pressure or temperature.

The data transmission frequency naturally also has an impact on the battery's service life.

1-second operation results in the longest time span.

The transmission frequency can also be checked visually: as soon as the transmission unit is switched on, the switch flashes each time data is transmitted.

7.3.4 Installation of the transmission unit on the EASY GTM bowl



NOTICE

The threaded holes inside the bowl, the passage holes and the Allen screws in the locking ring have to be cleaned thoroughly after each grinding to allow a safe fastening of the EASY GTM system.

The EASY GTM system has to be assembled as follows before inserting the EASY GTM system in the planetary mill:



1. ➤ Insert the O-ring (8) into the bowl (9). Make sure the sealing surface is clean thereby.
2. ➤ Insert filter lid (7) and insert seal (6).
3. ➤ Mount filter lid with 4 hexagon screws and retaining rings.
4. ➤ Put on the transmitter with seal.



5. → Tighten the hexagon screws crosswise with a torque spanner until it clicks (2.6 Nm). To be on the safe side, re-tighten all screws again after initially tightening them. All screws are secured against becoming loose during the grinding process once they have been tightened with the torque spanner as described.



Fritsch GmbH assumes no guarantee for damage caused by grinding with loose screws!



6. → Switch on the transmitter with the On/Off button (A) (LED flashes blue).
7. → Place the support ring on the bowl.



NOTICE

Check the fitting of the transmission unit again after inserting the bowl!



NOTICE

You must check that the hexagon screws are sitting correctly during breaks in grinding. If screws have loosened, they must be re-tightened.

7.3.5 Inserting the EASY GTM system



1. → Place the EASY GTM system into the grinding bowl holder.



2. → The pressure piece has to be removed in order to use the Safe-Lock system for clamping.

Accessories

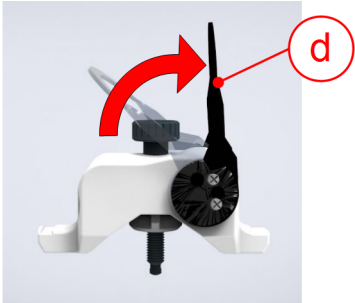

3. ➤ Position the bracket (d) vertically.

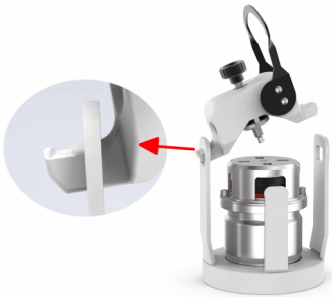

4. ➤ Hang the longer projection of the Safe-Lock clamping device into one side of the mounting of the grinding bowl holder.

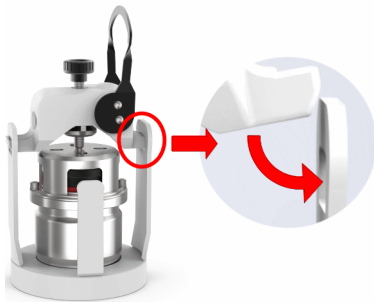

5. ➤ Hook the short projection of the Safe-Lock clamping device into the other side.

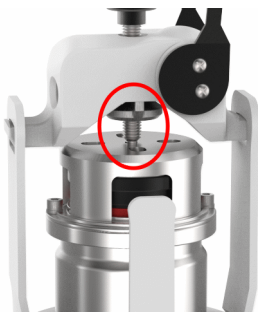

6. ➤ Ensure that the journal of the threaded spindle (where the pressure piece was previously affixed) is sitting in the bore hole provided in the support ring.

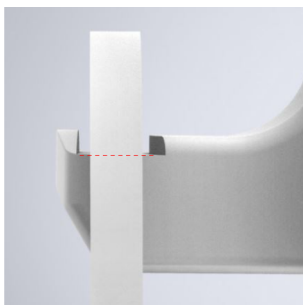

7. ➤ Push the Safe-Lock clamping device so that the mounting of the grinding bowl holder sits centrally in the U-shaped cut-out of the longer projection.

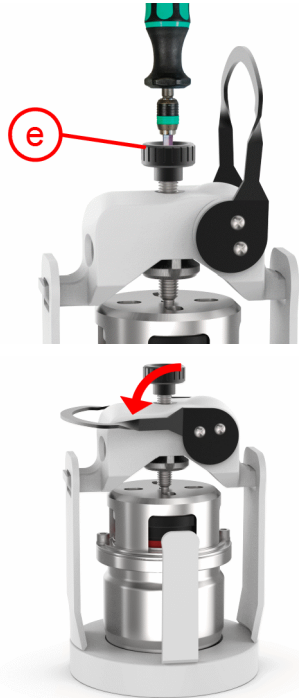

8. Pre-tension the setting screw (e) manually, and screw it tight using the provided torque spanner. Place the torque spanner provided on the setting screw (e) and turn until it clicks. (2.6 Nm)



Make sure that you do not turn the torque spanner too fast. This could prevent the correct final clamping force from being reached.

9. Then press the clamping lever downwards.
10. Wait a few seconds. Release the Safe-Lock again and turn the setting screw (e) again using the torque spanner until it clicks.
11. Press the clamping lever downwards again.
12. Re-tighten the screws of the filter lid with a hex key.



DANGER

After several minutes of grinding and in the cooling-down phases, check that the tensioning device is firmly connected.



If the Safe-Lock system is correctly tensioned, the clamping lever is automatically pulled downwards by the eccentric when horizontal.

7.3.6 Cleaning the EASY GTM system



NOTICE

The threaded holes inside the bowl, the passage holes and the Allen screws in the locking ring have to be cleaned thoroughly after each grinding to allow a safe fastening of the EASY GTM system.



NOTICE

The measuring/transmission unit should not be immersed in water. It can be rubbed down with a damp cloth if necessary.

Remove lock ring (2) incl. the screws from the measuring/transmission unit and remove all soiling.

Accessories

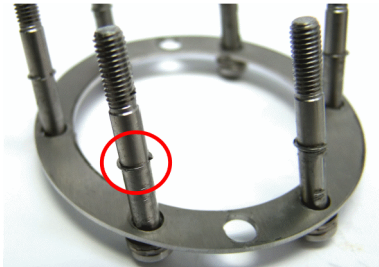

The screws are equipped with a circlip to prevent them from falling out of the lock ring (2). Ensure that the circlips are sitting correctly. (See illustration)

Insert lock ring.



7.3.6.1 Cleaning the sensor and replacing the seal



The sensor (G) must not be subjected to any mechanical stress. It is permitted to cleaning it with a wet cloth. The O-ring (5) can be replaced if necessary.

7.3.7 Battery arrangement

According to the "DIRECTIVE 2006/66/EC OF THE EUROPEAN PARLIAMENT AND COUNCIL as of 6th September 2006 on batteries and rechargeable batteries and on old batteries and old rechargeable batteries and for the annulment of Directive 91/157/EEC" and article 1, §18 and article 2 of the German Act on the re-definition of the waste legislation on the product responsibility for batteries and rechargeable batteries (BattG) as of 25.06.2009, we are legally obliged as the manufacturer to inform you as the consumer about the following:

The Easy GTM product we sell contains a lithium battery, type AA, 1.5V, that can be discharged once.

When the battery is flat, it may not be disposed of along with household waste. Old batteries may contain harmful substances that can pollute the environment or damage your health. Please deliver the batteries to the regional recycling point/collection point. Please only place discharged/flat batteries in the containers intended for this purpose. Cover the terminals of lithium batteries with adhesive tape first.

All batteries and rechargeable batteries are reused. Valuable substances, such as zinc, iron and nickel can thus be recycled. Battery recycling is one of the easiest environmental protection measures. The crossed-out dustbin symbol means that (rechargeable) batteries may not be disposed of along with household waste.

You can, of course, also return discharged batteries - with sufficient postage - by post to:

Fritsch GmbH

Milling and Sizing

Industriestrasse 8

D-55743 Idar-Oberstein, Germany

For information on removing the battery, see ➔ *Chapter 7.3.2 'Inserting / changing the battery' on page 50.*

8 Cleaning



DANGER

Mains voltage!

- Before beginning with cleaning work, disconnect the mains plug and protect the device against being unintentionally switched back on!
- Do not allow any liquids to flow into the device.
- Indicate cleaning work with warning signs.
- Put safety equipment back into operation after cleaning work.



When cleaning the entire device, adhere to the guidelines of the Accident Prevention Regulation (BGR A3) - especially when the device has been set up in a dusty environment or when the grinding stock processed produces dust.

8.1 Grinding elements



NOTICE

Cool grinding elements made of agate, sintered corundum, zirconium oxide and silicon nitride slowly and carefully.

Do not heat agate elements in a microwave under any circumstances (heating is too fast).

They must never be exposed to thermal shocks as this could cause irreparable damage to the parts → They will burst apart like in an explosion.

- Clean the grinding bowl and grinding balls each time after using them: Clean them, e.g., under running water using a brush and a commercially available cleaning agent.
- Half fill the grinding bowl with grinding balls, sand and water, and run with maximum speed for 2 to 3 minutes (correctly tensioned) in the Planetary mono mill.
- Cleaning with an ultrasonic cleaner is permitted.
- For sterilisation in the heat cabinet, only heat the grinding elements up to 100 °C.

8.2 Device

- The Planetary mono mill can be wiped down with a damp cloth when it is switched off.

9 Maintenance



⚠ DANGER

Mains voltage

- Before beginning with maintenance work, unplug the mains plug and protect the device against being unintentionally switched back on again!
- Indicate maintenance work with warning signs.
- Maintenance work may only be performed by specialised personnel.
- Put safety equipment back into operation after maintenance or repair work



NOTICE

Send all Safe-Lock clamping systems to Fritsch GmbH once a year for inspection. The customer must bear the costs of this maintenance itself.



We recommend keeping a safety logbook → Chapter 14 'Safety logbook' on page 71, where all work (maintenance, repairs.....) performed on the device is entered.



The most important element of maintenance is regular cleaning!

Functional part	Task or description	Test	Maintenance interval
Safety lock	Hood lock (7)	Is the closed hood (3) locked in place when the main switch is off? If this test is failed, do not continue to work until the fault has been rectified.	Before each use
Rotating bearings	Permanent lubrication	Bearing clearance	Every 2,000 h or annually
Drive motor	Permanent lubrication	Bearing clearance	Every 4,000 h or annually

Maintenance

Functional part	Task or description	Test	Maintenance interval
V-belt	Motor planetary disc	Check belt tension Disconnect the device from the mains. Screw off the (top) rear cover plate. The belt must not slacken by more than 10 mm when pushed with your thumb.	Once a year
Fan, ventilation slots	Grinding chamber cooling and electronics	Clean functional parts when soiled	Twice a year
Grinding bowl tensioning device, Safe-Lock (5)	Rubber of the pressure piece and rubber disc in the grinding bowl holder	Signs of use; replace if pressed flat and no longer elastic	After every 1,000 h
	Indicated surfaces of Safe-Lock are round Original height, 12.5 mm Minimum height, 12 mm (y)	Safe-Lock has frequently been tensioned too loosely	After every 200 h If the height is under the minimum height, the corresponding part has to be replaced.
Grinding bowl lid seal	Seal the grinding bowl	Replace seal if dirt has penetrated	After every 100 h
Grinding bowl holder (8)	Keep tension Original height, 14 mm	Minimum measurement at grinding bowl holder, 11 mm (x)	Twice a year; this minimum measurement may have to be checked more often depending on use. If the height is under the minimum height, the corresponding part has to be replaced.



Abb. 1



Abb. 2

10 Repairs

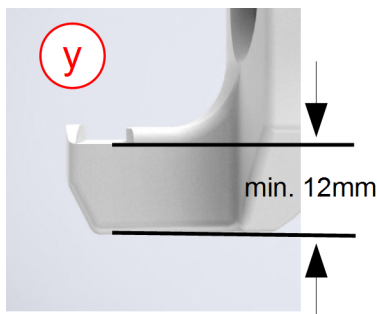

⚠ DANGER

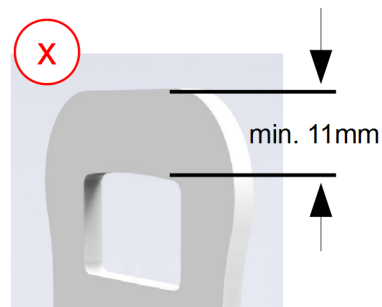
Mains voltage!

- Before beginning with repair work, unplug the mains plug and protect the device against being unintentionally switched back on.
- Indicate repair work with warning signs.
- Repair work may only be performed by specialised personnel.
- Put safety equipment back into operation after maintenance work.

10.1 Checklist for troubleshooting

Fault description	Cause	Remedy
Mill does not start up	No mains connection	Plug in mains plug.
	Main switch (10) at 0 (OFF)	Switch on main switch.
	Device fuse	Check device fuse; fuse insert on the back side of device 2 x 10 A T (12).
"START" button is pressed but mill does not start up	Check if POWER SUPPLY is lit	See → Chapter 4 'Installation' on page 19.
	Pause time active	Wait for end of pause or press "STOP".
	Safety lock (7) was opened manually	See → Chapter 2.6.1 'Opening the hood without mains connection' on page 13.
Mill reduces speed automatically	If REDUCED SPEED is lit: Overload	Reduce load or accept automatically set speed.
Mill stops running	Switched off due to thermal overload of the drive	Allow device to cool down and select a lower speed.
	Imbalance of machine too high	Improve mass balance. (See → Chapter 6.6 'Mass balance' on page 36).
	Drive was blocked	Rectify malfunction in grinding chamber.
	Motor's V-belt loose or ripped	Check V-belt, replace if necessary.
	Speed sensor is defective	Contact customer service.
The hood cannot be opened	The button (1) on the front of the hood was not actuated when opening.	Actuate button when opening.
	No mains connection	Plug in mains plug.
	Main switch (10) at 0 (OFF)	Switch on main switch (I).

Repairs

Fault description	Cause	Remedy
The hood cannot be opened	Device fuse	Check device fuse; fuse insert on the back side of device 2 x 10 A T (12).
Grinding stock escapes	Tensioning device (5) loose	Check and re-tension if necessary.
	Seal ring is soiled or defective	Clean or replace seal ring.
Runs unevenly with strong vibrations	Masses balanced inadequately	Set mass balance more adequately: See <i>↪ Chapter 6.6 'Mass balance' on page 36.</i>

11 Examples of comminution tasks

Material			
Feeding amount	Material of grinding bowl and balls	Grinding balls, St. x diameter	Result
Feed size	Grinding bowl size	Grinding duration	Final fineness
Ruby (stone)			
140 g	Cr-Ni steel	6 x 30 mm	100%
12 mm	250 ml	3 min	< 250 µm
Titanium dioxide TiO₂ (dry and wet grinding in water)			
40 g	Cr-Ni steel	6 x 30 mm	100%
2 mm	250 ml	30 min	< 40 µm
Titanium dioxide TiO₂ (wet grinding in water)			
40 g / 50 ml water	Cr-Ni steel	6 x 30 mm	100%
2 mm	250 ml	60 min	< 10 µm
Coal (dry and wet grinding in water)			
5 g	Zirconium oxide	5 x 20 mm	100%
0.5 mm	80 ml	120 min	< 15 µm
Aluminium oxide / silicon oxide			
100 g	WC + Co	15 x 20 mm	90%
0.1 mm	250 ml	90 min	< 20 µm
Ferrovandium			
70 g	WC + Co	5 x 30 mm	70%
3 mm	250 ml	20 min	< 100 µm
Glass			
50 g	Agate	15 x 20 mm	100%
4 mm	250 ml	15 min	< 90 µm
Silicon carbide (dry and wet grinding in water)			
15 g	WC + Co	5 x 20 mm	100%
3 mm	80 ml	30 min	< 150 µm

Examples of comminution tasks

Silicon carbide (dry and wet grinding in water)			
15 g / 5 ml water	WC + Co	5 x 20 mm	100%
3 mm	80 ml	45 min	< 71 µm
Raw phosphate			
40 g	Cr steel	15 x 20 mm	100%
3 mm	250 ml	2 min	< 250 µm
Manganese dioxide MnO₂ (wet grinding in water)			
50 g / 40 ml water	WC + Co	15 x 20 mm	100%
0.1 mm	250 ml	60 min	< 20 µm
Sludge (dry)			
180 g	Al ₂ O ₃	10 x 30 mm	100%
8 mm	500 ml	30 min	< 250 µm
Active carbon (wet grinding in water)			
150 ml	Cr-Ni steel	15 x 20 mm	100%
0.025 mm	250 ml	30 min	< 5 µm
Plaster			
300 g	Cr steel	10 x 30 mm	100%
10 mm	500 ml	20 min	< 200 µm
Protein			
50 g	Sintered corundum 1	6 x 30 mm	90%
20 mm	250 ml	90 min	< 50 µm
Grains (barley)			
100 g	Sintered corundum 1	3 x 40 mm	100%
3 mm	500 ml	20 min	< 150 µm
Dough products			
100 g	Sintered corundum 1	10 x 30 mm	100%
5 mm	500 ml	3 min	< 250 µm
Sugar (wet grinding in alcohol)			

Examples of comminution tasks

200 g	Agate	10 x 30 mm	100%
1 mm	500 ml	45 min	< 10 μm

12 Disposal

It is hereby confirmed that FRITSCH has implemented the directive 2002/95/EC of the European Parliament and Council from 27th January 2003 for the limitation of the use of certain dangerous substances in electrical and electronic devices.

FRITSCH has registered the following categories according to the German electrical and electronic equipment act, section 6, paragraph 1, clause 1 and section 17, paragraphs 1 and 2:

Mills and devices for the preparation of samples have been registered under category 6 for electrical and electronic tools (except for large stationary industrial tools).

Analytical devices have been registered under category 9, monitoring and control instruments.

It has been accepted that FRITSCH is operating only in the business-to-business area. The German registration number for FRITSCH is WEEE reg. no. DE 60198769

FRITSCH WEEE coverage

Since the registration of FRITSCH is classified for bilateral transactions, no legal recycling or disposal process is described. FRITSCH is not obliged to take back used FRITSCH devices.

FRITSCH declares it is prepared to take back used FRITSCH devices for recycling or disposal free of charge whenever a new device is purchased. The used FRITSCH device must be delivered free of charge to a FRITSCH establishment.

In all other cases FRITSCH takes back used FRITSCH devices for recycling or disposal only against payment.

13 Guarantee terms

Guarantee period

As manufacturer, FRITSCH GmbH provides – above and beyond any guarantee claims against the seller – a guaranty valid for the duration of two years from the date of issue of the guarantee certificate supplied with the device.

Within this guarantee period, we shall remedy all deficiencies due to material or manufacturing defects free of charge. Rectification may take the form of either repair or replacement of the device, at our sole discretion. The guarantee may be redeemed in all countries in which this FRITSCH device is sold with our authorisation.

Conditions for claims against the guarantee

This guarantee is subject to the condition that the device is operated according to the instructions for use / operating manual and its intended use.

Claims against the guarantee must include presentation of the original receipt, stating the date of purchase and name of the dealer, together with the complete device type and serial number.

For this guarantee to take effect, the answer card entitled "Securing of Guarantee" (enclosed with the device) must be properly filled out and despatched without delay after receipt of the device and be received by us within three weeks or alternatively, *online registration* must be carried out with the above-mentioned information.

Reasons for loss of the guarantee

The guarantee will not be granted in cases where:

- Damage has arisen due to normal wear and tear, especially for wear parts, such as: Crushing jaws, support walls, grinding bowls, grinding balls, sieve plates, brush strips, grinding sets, grinding disks, rotors, sieve rings, pin inserts, conversion kits, sieve inserts, bottom sieves, grinding inserts, cutting tools, sieve cassettes, sieve and measuring cell glasses.
- Repairs, adaptations or modifications were made to the device by unauthorized persons or companies.
- The device was not used in a laboratory environment and/or has been used in continuous operation.
- Damage is present due to external factors (lightning, water, fire or similar) or improper handling.
- Damage is present that only insubstantially affects the value or proper functioning of the device.
- The device type or serial number on the device has been changed, deleted, removed or in any other way rendered illegible
- The above-mentioned documents have been changed in any way or rendered illegible.

Costs not covered by the guarantee

This guarantee excludes any costs for transport, packaging or travel that accrue in the event the product must be sent to us or in the event that one of our specialist technicians is required to come to your site. Any servicing done by persons not authorised by us and any use of parts that are not original FRITSCH accessories and spare parts will void the guarantee.

Further information about the guarantee

The guarantee period will neither extend nor will a new period of guarantee begin in the event that a claim is placed against the guarantee.

Guarantee terms

Please provide a detailed description of the type of error or the complaint. If no error description is enclosed, we shall interpret the shipment as an assignment to remedy all recognisable errors or faults, including those not covered by the guarantee. Errors or faults not covered by the guarantee shall in this case be rectified at cost.

We recommend reading the operating manual before contacting us or your dealer, in order to avoid unnecessary inconvenience.

Ownership of defective parts is transferred to us with the delivery of the replacement part; the defective part shall be returned to us at buyer's expense.



NOTICE

Please note that in the event that the device must be returned, the device must be shipped in the original Fritsch packaging. Fritsch GmbH denies all liability for any damage due to improper packaging (packaging not from Fritsch).

Any enquiries must include a reference to the serial number imprinted on the type plate.

15 Index

A		I	
Accident prevention.	8	Imbalance detection.	16
Additional clamping system.	42	Initial start-up.	24
Adjusting to the mains voltage.	22	Inserting the battery into the EASY GTM system.	50
Adjustment options of the transmitter detection.	53	Installation of transmission unit.	54
Authorised persons.	8	Installing valve inserts.	48
B		M	
Ball		Maintenance.	61
Number.	31	Material.	18
Size.	31	N	
Battery arrangement.	58	Number of balls per bowl.	28
C		O	
Clamping 80 ml bowls.	35	Opening the hood without mains connection.	13
Clamping grinding bowl with the "Safe-Lock" clamping device	33	Operating noise.	17
Cleaning grinding elements.	60	Operating principle.	9
Cleaning the mill.	60	Overload.	40
Cleaning the sensor.	58	Overload protection.	16
Cleaning the valves.	48	P	
Conducting a grinding operation.	40	Power consumption.	17
Configuration of transmitter ID.	53	Preparing gassing.	46
Cooling grinding bowls.	41	Protection against restart.	16
Current consumption.	17	Protective equipment.	13
D		R	
Dimensions.	17	Repairs.	63
Disposal.	68	Repetition of grinding / pause cycles.	39
Dry grinding.	32	Replacing the seal.	58
E		Requirements for the user.	8
EASY GTM.	49	Reverse mode.	31, 39
Cleaning.	57	Rotational speed.	31
Electrical safety.	17	S	
Examples of comminution tasks.	65	Safety information.	10
Explanation of signs.	10	Safety logbook.	71
Explanation of symbols.	10	Scope of application.	8
F		Scope of delivery	
Filling quantity of grinding bowls.	29	EASY GTM.	50
Final fineness.	18	Setting the grinding duration.	38
G		Setting the speed.	37
Grinding balls		Setting up.	20
Selecting.	25	Size of the grinding balls.	26
Grinding bowl		Skilled workers.	8
Filling.	30	Stand By - Mode.	41
Selecting.	25	T	
Grinding in inert gas.	46	Transmission frequency setting options.	53
Grinding time.	30, 36	Troubleshooting checklist.	63
Guarantee terms.	69	U	
H		Unpacking.	19
Hazardous points.	15		

Index

V

Ventilating after grinding.....	47
Voltage.....	17

W

Warning information.....	10
WEEE.....	68
Weight.....	17
Wet grinding.....	32



© 2014

Fritsch GmbH

Milling and Sizing

Industriestrasse 8

D - 55743 Idar-Oberstein

Telephone: +49 6784 70-0

Email: info@fritsch.de

Internet: www.fritsch.de
