

# Operating instructions

## MINI-MILL

### PULVERISETTE 23

Valid starting with: 23.1000/101



Read the instructions prior to performing any task!



Fritsch GmbH  
Milling and Sizing  
Industriestraße 8  
D - 55743 Idar-Oberstein  
Telephone: +49 6784 70-0  
Email: [info@fritsch.de](mailto:info@fritsch.de)  
Internet: [www.fritsch.de](http://www.fritsch.de)

## Certifications and CE conformity

### Certification

Fritsch GmbH has been certified by the SGS-TÜV Saar GmbH.



An audit certified that Fritsch GmbH conforms to the requirements of the DIN EN ISO 9001:2015.

### CE Conformity

The enclosed Conformity Declaration lists the guidelines the FRITSCH instrument conforms to, to be able to bear the CE mark.



## Table of contents

<b>1</b>	<b>Basic structure</b> .....	<b>6</b>
<b>2</b>	<b>Safety information and use</b> .....	<b>7</b>
	2.1 Requirements for the user .....	7
	2.2 Scope of application .....	7
	2.2.1 Operating principle .....	8
	2.3 Obligations of the operator .....	8
	2.4 Information on hazards and symbols used in this manual .....	9
	2.5 Device safety information .....	11
	2.6 Hazardous points .....	12
	2.7 Electrical safety .....	12
	2.7.1 General information .....	12
	2.7.2 Protection against restart .....	12
	2.7.3 Overload protection .....	12
<b>3</b>	<b>Technical data</b> .....	<b>13</b>
	3.1 Dimensions .....	13
	3.2 Weight .....	13
	3.3 Operating noise .....	13
	3.4 Voltage .....	13
	3.5 Current consumption .....	13
	3.6 Protection class .....	13
	3.7 Power consumption .....	13
	3.8 Electrical fuses .....	13
	3.9 Material .....	13
	3.10 Final fineness .....	14
<b>4</b>	<b>Installation</b> .....	<b>15</b>
	4.1 Transport .....	15
	4.2 Unpacking .....	15
	4.3 Setting up .....	15
	4.4 Ambient conditions .....	16
	4.5 Electrical connection .....	16
	4.6 Changing the timer .....	16
<b>5</b>	<b>Initial start-up</b> .....	<b>17</b>
	5.1 Switching on .....	17
	5.2 Function check .....	17
	5.3 Switching off .....	17

<b>6</b>	<b>Using the device. . . . .</b>	<b>18</b>
6.1	Choice of grinding bowls and grinding balls. . . . .	18
6.1.1	Size of the grinding balls. . . . .	18
6.1.2	Number of balls per grinding bowl (independent of the material quantity). . . . .	19
6.1.3	Calculated weight of a ball. . . . .	19
6.2	Filling the grinding bowl. . . . .	19
6.2.1	Types of grinding bowls. . . . .	20
6.3	Factors with an impact on grinding. . . . .	21
6.3.1	Running time (grinding duration). . . . .	21
6.3.2	Vibration frequency. . . . .	21
6.3.3	Number and size of the balls. . . . .	21
6.3.4	Weight of the balls (type of material). . . . .	22
6.4	Dry grinding. . . . .	22
6.5	Wet grinding (grinding in a suspension). . . . .	22
6.6	Clamping the grinding bowls. . . . .	23
6.7	Grinding duration. . . . .	23
6.8	Control panel. . . . .	23
6.8.1	Setting the vibration frequency. . . . .	23
6.8.2	Setting the running time. . . . .	24
6.9	Conducting a grinding operation. . . . .	24
<b>7</b>	<b>Cleaning. . . . .</b>	<b>25</b>
7.1	Grinding elements. . . . .	25
7.2	Mill. . . . .	25
<b>8</b>	<b>Maintenance. . . . .</b>	<b>26</b>
<b>9</b>	<b>Repairs. . . . .</b>	<b>28</b>
9.1	Checklist for troubleshooting. . . . .	28
<b>10</b>	<b>Disposal. . . . .</b>	<b>29</b>
<b>11</b>	<b>Guarantee terms. . . . .</b>	<b>30</b>
<b>12</b>	<b>Exclusion of liability. . . . .</b>	<b>32</b>
<b>13</b>	<b>Safety logbook. . . . .</b>	<b>34</b>
<b>14</b>	<b>Index. . . . .</b>	<b>35</b>

# 1 Basic structure

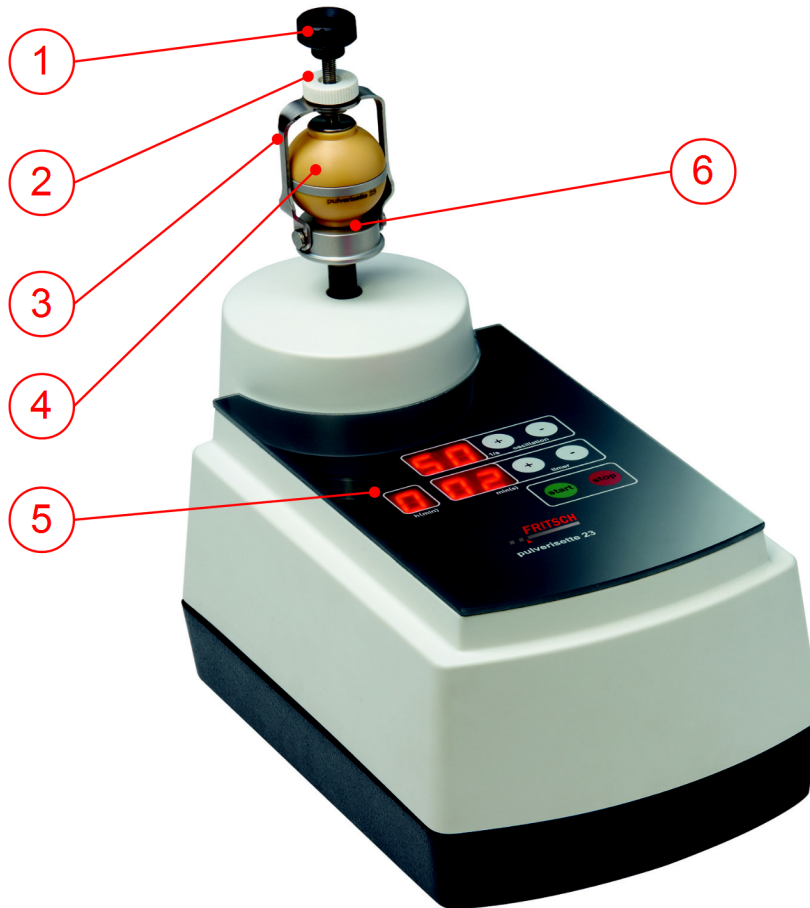

- 1 Knurled screw
- 2 Knurled nut
- 3 Clamping bracket
- 4 Grinding bowl
- 5 Control panel
- 6 Rubber disk

## 2 Safety information and use

### 2.1 Requirements for the user

This operating manual is intended for persons assigned with operating and monitoring the Fritsch PULVERISETTE 23. The operating manual and especially its safety instructions are to be observed by all persons working on or with this device. In addition, the applicable rules and regulations for accident prevention at the installation site are to be observed. Always keep the operating manual at the installation site of the PULVERISETTE 23.

People with health problems or under the influence of medication, drugs, alcohol or exhaustion must not operate this device.

The PULVERISETTE 23 may only be operated by authorised persons and serviced or repaired by trained specialists. All commissioning, maintenance and repair work may only be carried out by technically qualified personnel. Qualified personnel are persons who, because of their education, experience and training as well as their knowledge of relevant standards, regulations, accident prevention guidelines and operating conditions, are authorised by those responsible for the safety of the machine to carry out the required work and are able to recognize and avoid possible hazards as defined for skilled workers in IEC 364.

In order to prevent hazards to users, follow the instructions in this manual.

Malfunctions that impair the safety of persons, the PULVERISETTE 23 or other material property must be rectified immediately. The following information serves both the personal safety of operating personnel as well as the safety of the products described and any devices connected to them: All maintenance and repair work may only be performed by technically qualified personnel.

This operating manual is not a complete technical description. Only the details required for operation and maintaining usability are described.

Fritsch has prepared and reviewed this operating manual with the greatest care. However, no guarantee is made for its completeness or accuracy.

Subject to technical modifications.

### 2.2 Scope of application



#### NOTICE

This laboratory instrument is designed for an 8-hour shift operation at 30 % duty cycle and not for continuous operation.

The duty cycle is defined as the ratio of load duration to run time. The run time is defined as load duration plus pause time. According to DIN EN 60034-1 (VDE 0530, IEC34-1) a continuous operation already takes place after a standardised run time of 10 minutes. At 30 % duty cycle (DC = ratio of load duration to run time) a load duration of 3 minutes and a pause time of 7 minutes would be within standard.

If the standardised run time of 10 minutes is exceeded, then, by definition, there would be a continuous operation and disproportionate temperature increases may occur, possibly involving increased wear.

The PULVERISETTE 23 mini-mill can be applied universally for the fast dry or wet grinding of inorganic and organic samples for analysis, quality inspection or material testing.

During synthesis, the mini-mill mixes and homogenises dry samples, emulsions or pastes. With precise and continuous regulation of the vibration frequency and small grinding bowls made out of different materials, the device is also excellently suited for cell disruption for bioengineering.

### 2.2.1 Operating principle



The rapid vertical acceleration of the grinding bowl causes the grinding balls in the bowl to vibrate. Comminution occurs when the balls of grinding stock hit the walls of the bowl and each other. Due to the almost spherical grinding chamber the balls are not limited to vertical movement, and very efficient comminution is achieved.

### 2.3 Obligations of the operator

Before using the PULVERISETTE 23, this manual is to be carefully read and understood. The use of the PULVERISETTE 23 requires technical knowledge; only commercial use is permitted.

The operating personnel must be familiar with the content of the operating manual. For this reason, it is very important that these persons actually receive the present operating manual. Ensure that the operating manual is always near the device.

The PULVERISETTE 23 may exclusively be used within the scope of applications set down in this manual and within the framework of guidelines put forth in this manual. In case of non-compliance or improper use, the customer assumes full liability for the functional capability of the PULVERISETTE 23 and for any damage or injury arising from failure to fulfil this obligation.

By using the PULVERISETTE 23 the customer agrees with this and recognizes that defects, malfunctions or errors cannot be completely excluded. To prevent risk of damage to persons or property or of other direct or indirect damage, resulting from this or other causes, the customer must implement sufficient and comprehensive safety measures for working with the PULVERISETTE 23.

Neither compliance with this manual nor the conditions and methods used during installation, operation, use and maintenance of the PULVERISETTE 23 can be monitored by Fritsch GmbH. Improper execution of the installation can result in property damage and thus endanger persons. Therefore, we assume absolutely no responsibility or liability for loss, damage or costs that result from errors at installation, improper operation or improper use or improper maintenance or are in any way connected to these.

The applicable accident prevention guidelines must be complied with.

Generally applicable legal and other obligatory regulations regarding environmental protection must be observed.

## 2.4 Information on hazards and symbols used in this manual

### Safety information

Safety information in this manual is designated by symbols. Safety information is introduced by keywords that express the extent of the hazard.



#### DANGER

This symbol and keyword combination points out a directly hazardous situation that can result in death or serious injury if not avoided.



#### WARNING

This symbol and keyword combination points out a possibly hazardous situation that can result in death or serious injury if not avoided.



#### CAUTION

This symbol and keyword combination points out a possibly hazardous situation that can result in slight or minor injury if not avoided.



#### NOTICE

This symbol and keyword combination points out a possibly hazardous situation that can result in property damage if not avoided.



#### ENVIRONMENT

This symbol and keyword combination points out a possibly hazardous situation that can result in environmental damage if not avoided.

### Special safety information

To call attention to specific hazards, the following symbols are used in the safety information:



#### DANGER

This symbol and keyword combination points out a directly hazardous situation due to electrical current. Ignoring information with this designation will result in serious or fatal injury.



#### DANGER

This symbol and keyword combination designates contents and instructions for proper use of the machine in explosive areas or with explosive substances. Ignoring information with this designation will result in serious or fatal injury.

## Safety information and use



### DANGER

This symbol and keyword combination designates contents and instructions for proper use of the machine with combustible substances. Ignoring information with this designation will result in serious or fatal injury.



### WARNING

This symbol and keyword combination points out a directly hazardous situation due to movable parts. Ignoring information with this designation can result in hand injuries.



### WARNING

This symbol and keyword combination points out a directly hazardous situation due to hot surfaces. Ignoring information with this designation can result in serious burn injuries due to skin contact with hot surfaces.

### Safety information in the procedure instructions

Safety information can refer to specific, individual procedure instructions. Such safety information is embedded in the procedure instructions so that the text can be read without interruption as the procedure is being carried out. The keywords described above are used.

Example:

1.  Loosen screw.

2. 



### CAUTION

Risk of entrapment at the lid.

Close the lid carefully.

3.  Tighten screw.

### Tips and recommendations



*This symbol emphasises useful tips and recommendations as well as information for efficient operation without malfunction.*

### Further designations

To emphasise procedure instructions, results, lists, references and other elements, the following designations are used in this manual:

Designation	Explanation
 1., 2., 3. ...	Step-by-step procedure instructions

Designation	Explanation
⇒	Results of steps in the procedure
☞	References to sections in this manual and relevant documentation
■	Lists without a specific order
[Button]	Operating elements (e.g. push button, switch), display elements (e.g. signal lamps)
'Display'	Screen elements (e.g. buttons, function key assignment)

## 2.5 Device safety information

Please observe!

- Only use original accessories and original spare parts. Failure to observe this instruction can compromise the safety of the machine.
- Accident-proof conduct is to be strictly followed during all work.
- Comply with all currently applicable national and international accident prevention guidelines.



### CAUTION

#### Wear hearing protection!

If a noise level of 85 dB(A) is reached or exceeded, ear protection should be worn to prevent hearing damage.



### WARNING

The maximum accepted concentration (MAC) levels of the relevant safety guidelines must be observed; if necessary, ventilation must be provided or the machine must be operated under an extractor hood.



### DANGER

#### Explosion hazard!

- When grinding oxidizable substances, e.g. metals or coal, there is a risk of spontaneous combustion (dust explosion) if the share of fine particles exceeds a certain percentage. When grinding these kinds of substances, special safety measures must be taken and the work must be supervised from a specialist.
- The PULVERISETTE 23 is not explosion protected and is not designed to grind explosive materials.

- Do not remove the information signs.



**NOTICE**

Immediately replace damaged or illegible information signs.

- Unauthorised alteration of the PULVERISETTE 23 will void Fritsch's declaration of conformity to European directives and void the guarantee.
- Only use the PULVERISETTE 23 when it is in proper working order, as intended and in a safety- and hazard-conscious manner adhering to the operating manual. In particular, immediately rectify any malfunctions that could pose a safety hazard.
- If, after reading the operating manual, there are still questions or problems, please do not hesitate to contact our specialised personnel.

## 2.6 Hazardous points

- Because the grinding container operates uncovered for better heat dissipation, there is a risk of impact if the grinding bowl or the fixture is touched during the grinding process. Bear this in mind when starting the operation in particular. Always turn the main switch to "Off" before working on the grinding bowl clamp to prevent the START button from being unintentionally activated.
- Crushing hazard when clamping the grinding bowl.

## 2.7 Electrical safety

### 2.7.1 General information

The main switch disconnects the mini-mill from the 24 V external power supply. If the device is going to be out of use for a longer period of time, remove the mains plug from the 24 V power supply.

### 2.7.2 Protection against restart

The device is safeguarded against restarting after a power failure.

### 2.7.3 Overload protection

The device has internal excess current protection and switches off in the event of overload.

### 3 Technical data

#### 3.1 Dimensions

280 x 150 x 270 mm (height x width x depth)

#### 3.2 Weight

approx. 7.35 kg (net)

approx. 9 kg (gross)

#### 3.3 Operating noise

Emissions value of workplace according to DIN EN ISO 3746:2005  $L_{Pa} = 64.4$  dB(A). The noise level measurement was conducted with sand as grinding stock and grinding elements made of zirconium oxide.

#### 3.4 Voltage

The device is operated with an external 24 V switch-mode power supply. The switch-mode power supply is configured for a wide voltage range of 100-240 V. No adjustments are required for the country-specific voltage and mains frequency.

#### 3.5 Current consumption

The maximum current consumption of the external power supply is approx. 0.41 A.

#### 3.6 Protection class

IP 42

#### 3.7 Power consumption

The maximum power consumption of the external power supply is approx. 40 VA / 20 W.

#### 3.8 Electrical fuses

Internal excess current protection in the power supply and in the device.

#### 3.9 Material

- Maximum feeding size 6 mm
- Maximum feeding amount 5 ml

### 3.10 Final fineness

$d_{50} = 5 \mu\text{m}$  for wet grinding depending on the sample materials for comminution.

## 4 Installation

### 4.1 Transport

The device is delivered in a cardboard box.

The guarantee excludes all claims for damage due to improper transport.

### 4.2 Unpacking



#### NOTICE

**Do not** take the PULVERISETTE 23 out of the packaging by the grinding bowl holder!

- Compare the contents of the delivery with your order.
- Please store the transport packaging so that it can be reused if you need to return the product. Fritsch GmbH accepts no liability for damage caused by improper packaging (packaging that is not from Fritsch).
- Lift the device out of the packaging by gripping the underside of the device. Do not lift it up by the grinding bowl holder.

### 4.3 Setting up



#### NOTICE

Allow the device to acclimatise for two hours before commissioning. High temperature differences can lead to condensation in the device and damage to the electronics after switching on.

Strong temperature fluctuations can occur during transport or interim storage. Depending on the temperature difference between the installation site and the transport or storage environment, condensation can form inside the device. This can damage the electronics if the devices are switched on too early. Wait for at least two hours after setup before switching on the device.

Place the device on a flat, stable surface. It is not necessary to fasten it in place. Leave space to the right for the 24 V connection and the main switch. The vents under the device must remain unobstructed.

#### 4.4 Ambient conditions



 **WARNING**

**Mains voltage!**

- The device may only be operated indoors.
- The surrounding air may not carry any electrically conductive dust.
- Maximum relative humidity 80% for temperatures up to 31°C, linearly decreasing down to 50% relative humidity at 40°C.

- The room temperature has to stay between 5 - 40°C.
- Altitudes up to 2000 m
- Degree of pollution 2 according to IEC 664.

#### 4.5 Electrical connection

Before establishing the connection, compare the voltage and current values stated on the type plate of the power supply with the values of the mains system to be used.



**CAUTION**

Ignoring the values on the type plate may result in damage to the electrical and mechanical components.

#### 4.6 Changing the timer

By holding down the STOP button (for 5 seconds) you can access the setup mode where the time fields hours/minutes or minutes/seconds can be set. Using the +/- buttons, it is possible to set the timer to the hours/minutes mode with 0 or to the minutes/seconds mode with 1. Press the STOP button to return to the normal operating mode. The device is factory set to the hours/minutes mode. It is essential to observe the pause times to allow the device to cool when it is in continuous operation for an hour or more or under high loads. When the device is in operation for over 10 minutes the grinding bowl and the device heat up significantly.

## 5 Initial start-up

Perform initial start-up only after all work as described in *Chapter 4 'Installation'* on page 15 has been carried out.

### 5.1 Switching on



#### NOTICE

Before switching the device on make sure that a grinding bowl or the transport wood is clamped into the grinding bowl holder. The loose grinding bowl holder can damage the housing.

- Connect the external power supply to the mains and the low voltage plug to the bottom right of the device.
- Switch the device on at the housing. The display lights up.

### 5.2 Function check



*The glass plate has capacitive buttons, which are sensitive to touch.*

- Clamp an empty grinding bowl (see *Chapter 6.6 'Clamping the grinding bowls'* on page 23).
- Set a short grinding time and a frequency of approx. 30 Hz with the corresponding +/- buttons (see *Chapter 6.8.1 'Setting the vibration frequency'* on page 23).
- Press the START button to run the mill at the preselected vibration frequency.
- The timer counts the time; the time remaining is displayed. At the end of this time the device will stop.

### 5.3 Switching off

- Press the STOP button and switch off the main switch.

## 6 Using the device

### 6.1 Choice of grinding bowls and grinding balls



**CAUTION**

If the grinding elements used are not genuine accessories, we assume no guarantee and exclude all liability for damage to the device or for personal injury.

To prevent excessive wear caused by abrasion, the hardness and density (specific weight) of the grinding bowl and grinding balls used must be greater than that of the material used.

Material (bowl and balls)	Main components of the material	Density in g/cm <sup>3</sup>	Abrasion resistance	Use for grinding stock
Zirconium oxide	(96,2% ZrO <sub>2</sub> )	5.7	Very good	Fibrous, abrasive samples
Hardened, stainless steel	16,0 - 18,0 % Cr	7.7	Fairly good	Medium-hard, brittle samples
PTFE		2,2	Fairly good	Soft, brittle samples

It is recommended to choose a grinding bowl and grinding balls that are made of the same material.

#### 6.1.1 Size of the grinding balls

Type of feed material	Suitable ball diameter
Hard samples with a maximum feed size of 2-5 mm	15 mm
Fine material < 0.5 mm	10 mm or smaller
Homogenisation of dry or liquid samples	10 mm or smaller

**These are reference values: The size of bowls and grinding balls may need to be determined through experimentation.**



**NOTICE**

It is not advisable to mix balls of different diameters. (If balls with different diameters are used, increased wear to the balls is to be expected.)

### 6.1.2 Number of balls per grinding bowl (independent of the material quantity)

A higher number of balls will reduce the grinding duration and the grinding results will be within a smaller grain size range.

Ball diameter (mm)	Grinding bowl volume (ml)	30	15	10	5	2 (single use)
1	Weight of the balls (g)	30 g	15 g	10 g	5 g	3 g
5	Number of balls (pcs)	70	60	30	20	-
10	Number of balls (pcs)	10	5	3	1	-
15	Number of balls (pcs)	4	2	1	-	-

The number of balls should be complied with to avoid unnecessary wear.

### 6.1.3 Calculated weight of a ball

Ball diameter in mm		5	10	15
Material	Density in g/cm <sup>3</sup>	Calculated weight of a ball in g		
Zirconium oxide	5,9	0,37	2,98	10,07
Stainless steel	7,8	0,51	4,08	13,78
Hardened steel	7,9	0,52	4,14	13,96

To determine the weight of the required balls, the "calculated weight of a ball" is multiplied by the "number" of balls required.

Example: A 10 ml zirconium oxide bowl is to be filled with 30 zirconium oxide balls with a diameter of 5 mm.

Calculation:  $0.37 \text{ g} * 30 \text{ St} = 11.1 \text{ g}$

11.1 g of grinding balls can be weighed and inserted in the grinding bowl, thus avoiding the time required for counting the balls.

## 6.2 Filling the grinding bowl



#### NOTICE

Fill a maximum of 1/2 the volume of the grinding bowl with grinding balls and grinding stock.

## Using the device

**Do not fail to comply with the following sequence:**

1. ➤ Place the grinding balls in the empty bowl.
2. ➤ Pour grinding stock onto the balls and possibly add liquid for wet grinding.



*All sealing surfaces must be absolutely clean to guarantee impermeability, particularly during wet grinding. The best cleaning method is to use standard fleece.*

### 6.2.1 Types of grinding bowls

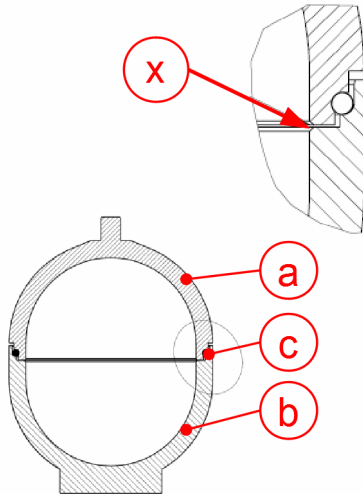

**Stainless steel and hardened steel:**

- a Grinding bowl lid
- b Grinding bowl
- c O-ring
- x A burr can form in this position!

- The bowl sealing surfaces must be clean.
- A burr can form on the inner edge of the stainless grinding bowl and lid after a lengthy grinding time. This burr has to be removed at an early stage with a scraper or fine emery paper (see also ➔ *Chapter 8 'Maintenance' on page 26*).
- Check the O-ring (c) of the lid seal for damage and proper insertion. The inner diameter of the O-ring is a bit smaller than the outer diameter of the base of the grinding bowl lid (a). The O-ring must therefore be stretched in order to attach it.
- Place the lid (a) with the seal attached (c) vertically onto the bowl (b); do not force it.

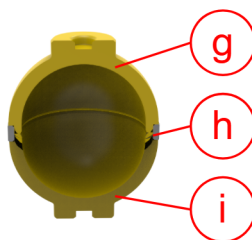

**Zirconium oxide:**

The seal is created by grinding the surfaces of the lid (g) and the bowl (i) to lie perfectly flush. Use a centre ring (h) to align both parts.

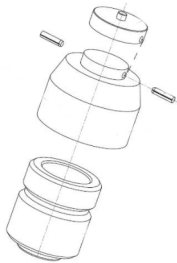

#### PTFE (Teflon):

The seal is created by grinding the surfaces of the lid and the bowl to lie perfectly flush. In addition, they are also screwed together. These bowls cannot be used for grinding hard sample materials. They are used to solubilise soft sample materials or mix and homogenise sample materials. The bowl can be cooled in liquid nitrogen.

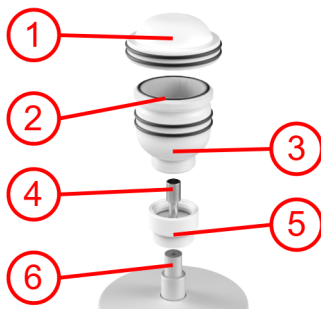

#### PTFE 30 ml:

The standard holder must be unscrewed and the new holder (5) must be screwed onto the thread (3) with the screw (4). You can then fill the 30 ml PTFE container (3), place the seal (2), screw the cup lid (1) onto the cup and screw the entire cup to the holder (5).

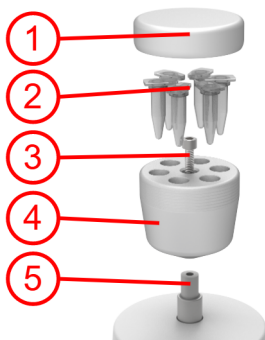

#### Single use container:

The standard holder must be unscrewed. Then screw the container (4) onto the mount (5) using the supplied screw (3). 6 tubes (2) with a volume of 0.5 ml, 1.5 ml or 2 ml can be inserted into the container. Finally, screw the lid (1) onto the container (4).

The number of balls to be used can be found in [Chapter 6.1.2 'Number of balls per grinding bowl \(independent of the material quantity\)'](#) on page 19.

## 6.3 Factors with an impact on grinding

### 6.3.1 Running time (grinding duration)

A longer grinding time will increase the percentage of fine material. To reduce the grinding time, you can use a grinding bowl and grinding balls with a higher density, and thus a higher impact energy.

### 6.3.2 Vibration frequency

Higher vibration frequencies shorten the grinding time and increase the share of fine particles.

### 6.3.3 Number and size of the balls

Pre-grind course, hard material with large balls:

## Using the device

Reduced percentage of fine material!

Many small balls increase the percentage of fine material during extended grinding time.

### 6.3.4 Weight of the balls (type of material)

A higher mass (specific weight) of the grinding balls accelerates grinding. (see table in [Chapter 6.1 'Choice of grinding bowls and grinding balls'](#) on page 18).

## 6.4 Dry grinding

During dry grinding a bed of material with a fineness of approx. 20 µm forms on the balls and the walls of the grinding bowl after approx. 5-10 minutes, which prevents further comminution. The grinding stock begins to stick because the surface forces become too big.

If surface-active substances are added to the grinding stock, comminution can be carried out for longer and it is possible to achieve a higher share of fine material.

Examples (maximum amount to be added in mass%):

- Stearic acid 2-3%
- Aerosil (fine-particle silicic acid) 0.5-2%;
- Quartz sand 2%
- Glass powder 2%

Highly flammable and flammable liquids such as ketone and benzene with boiling points <80°C must not be used.

## 6.5 Wet grinding (grinding in a suspension)



### CAUTION

#### Burn hazard!

The grinding bowl can become hot during long grinding periods. Allow for cooling time after grinding.

Wear safety gloves!

A longer grinding time can be selected for wet grinding in suspension but beware of excessively high temperatures. High vapour pressure can develop in the grinding bowl; this escapes with sudden force when the clamping device is released.

## 6.6 Clamping the grinding bowls



### CAUTION

Make sure the main switch is switched off when working on the clamping device so that the device is not inadvertently switched on!

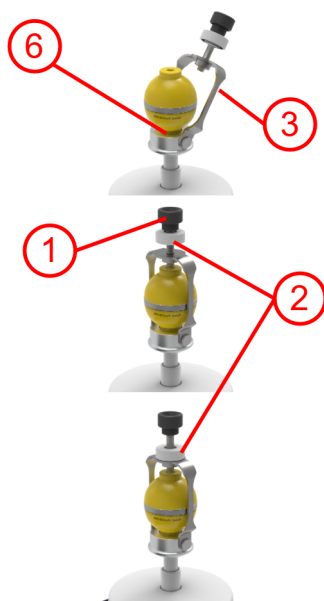

1. → Before clamping, check the rubber disk (6) in the base of the grinding bowl holder for any damage.
2. → Place the grinding bowl in the recess in the base of the grinding bowl holder on the rubber disk (6).
3. → Position the clamping bracket (3) vertically and tighten the knurled screw (1) hand-tight (not too loose and also without using too much force).
4. → Afterwards, counter with the knurled (2) nut.

## 6.7 Grinding duration

Depending on the use (high vibration frequency, heavy balls, long grinding duration) the grinding duration should be checked for a temperature increase of the grinding bowl by hand several times in five minute intervals. If the grinding bowl is too hot to touch, implement a cooling pause. Check that the clamping device is securely in place before switching on again. At lower vibration frequencies the grinding duration can be increased. No external time switches can be used due to the restart protection.

## 6.8 Control panel

### 6.8.1 Setting the vibration frequency

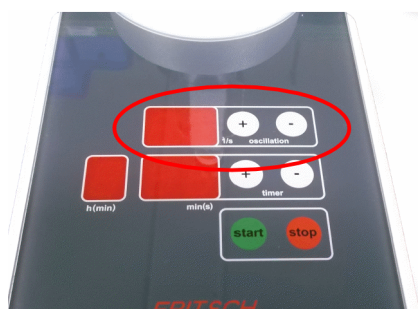

The vibration frequency can be set as 15-50 Hz (strokes per second) in 1 Hz steps using the +/- buttons (oscillation). The mill generates natural oscillation of higher or lower intensity depending on the stroke frequency. The set oscillation frequency is controlled by the microprocessor and thus guarantees reproducible grinding.

## Using the device

### 6.8.2 Setting the running time

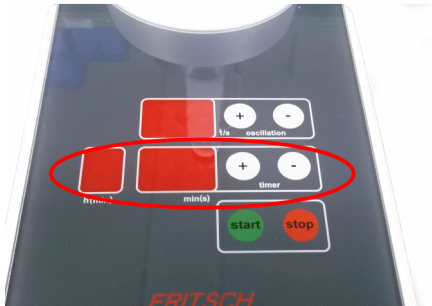

The running time is set using the +/- buttons (timer). In the factory set mode, the two right-hand numbers show the minutes and the left-hand number the hours. 9 hours 59 minutes is the maximum time which can be set. For grinding operations that are accurate to the second use the minutes/seconds timer (see [Chapter 4.6 'Changing the timer' on page 16](#)).

### 6.9 Conducting a grinding operation

After everything has been set up, as described in [Chapter 6 'Using the device' on page 18](#), press the START button on the control panel. Do not touch or disturb the grinding bowl or the clamping device during this time. The device will start up and run for the grinding time set on the timer. Grinding can be paused at any time by pressing the STOP button. The grinding running time on the timer stops and, once the START button is pressed, resumes, accurate to the second. This can be carried out, for example, in order to check the bowl temperature or the clamping device. If the time is altered, the timer will be reset.

## 7 Cleaning

**! DANGER****Mains voltage!**

- Before beginning with cleaning work, disconnect the mains plug and protect the device against being unintentionally switched back on!
- Do not allow any liquids to flow into the device.
- Indicate cleaning work with warning signs.
- Put safety equipment back into operation after cleaning work.

**NOTICE**

Cool grinding elements made of zirconium oxide slowly and carefully.

They must never be exposed to thermal shocks as this could cause irreparable damage to the parts → They will burst apart with powerful force.

The seal ring has to be removed before sterilisation.

### 7.1 Grinding elements

- Clean the grinding bowl and grinding balls each time after using them: Clean them, e.g., under running water using a brush and a commercially available cleaning agent. It is recommended to use a wire basket or sieve with a narrow mesh width for small grinding balls.
- Take particular care to thoroughly dry hardened steel bowls and grinding balls with a towel after cleaning; otherwise there is a risk of corrosion.
- Cleaning with an ultrasonic cleaner is permitted.
- Only heat the drying cabinet up to 100 °C for sterilisation.

### 7.2 Mill

- The mini-mill can be wiped down with a damp cloth when the main switch is switched off. When the main switch is switched on there is a danger of unintended start up.

## 8 Maintenance



**⚠ DANGER**

**Mains voltage**

- Before beginning with maintenance work, unplug the mains plug and protect the device against being unintentionally switched back on again!
- Indicate maintenance work with warning signs.
- Maintenance work may only be performed by specialised personnel.
- Put safety equipment back into operation after maintenance or repair work.



*We recommend keeping a safety logbook → Chapter 13 'Safety logbook' on page 34, where all work (maintenance, repairs.....) performed on the device is entered.*



*The most important element of maintenance is regular cleaning!*

- In stainless grinding bowls a burr can form over time on the inner edge between the bowl and the lid due to the ductility of the material. This burr causes the bowl and the lid to rest on each other, metal against metal, and the O-ring seal ceases to function. If you notice burr formation, it should be removed immediately with a scraper or fine emery paper before the burr becomes so large that removing it is difficult and requires a lot of effort.

Functional part	Task	Test	Maintenance interval
Felt ring as piston seal	Sealing the piston bearing	Put a few drops of oil on the piston	Every 50 operating hours.
Drive motor	Permanent lubrication	Bearing clearance	Every 400 h or annually
Connection rod bearing	Permanent lubrication	Bearing clearance	Every 400 h or annually
Piston bearing	Maintenance free slide bearing	Bearing clearance	Every 400 h or annually
Spindle for the grinding bowl clamping device	Clamping the grinding bowls	Mobility, oil if necessary	Every 100 h
Grinding bowl holder	Rubber disk (6)	Signs of use	Every 100 h
	Clamping bracket (3)	Realign or replace if bent	

Functional part	Task	Test	Maintenance interval
	O-ring seal for the grinding bowl	If deformed, frayed or torn	

## 9 Repairs



**! DANGER**

**Mains voltage!**

- Before beginning with repair work, unplug the mains plug and protect the device against being unintentionally switched back on.
- Indicate repair work with warning signs.
- Repair work may only be performed by specialised personnel.
- Put safety equipment back into operation after maintenance work.

### 9.1 Checklist for troubleshooting

Fault description	Cause	Remedy
No display	No mains connection, main switch "Off".	Plug in mains plug. Switch on main switch.
Mill reduces speed	Mechanical overload	Press STOP button
	When the piston gets too hot it expands and becomes too stiff.	Reduce the load. Allow it to cool down.
Mill stops running	Switched off due to thermal overload of the drive.	Allow the device to cool down.
	Drive was blocked	Clear the jam in the device.
	Speed sensor is defective	Call customer service.
Grinding stock escapes	Clamping device loose	Tighten clamping device.
	Seal ring defective or not inserted properly.	Insert the seal properly or replace it.
	Burr formation on the stainless grinding bowls.	Remove the burr with a scraper or fine emery paper.
	Sealing surfaces are soiled.	Cleaning the sealing surfaces. The best cleaning method is to use standard fleece.
	Centre ring not inserted or soiled. (Only for ZrO <sub>2</sub> )	Insert the centre ring properly or clean it.

## 10 Disposal

It is hereby confirmed that FRITSCH has implemented the directive 2002/95/EC of the European Parliament and Council from 27th January 2003 for the limitation of the use of certain dangerous substances in electrical and electronic devices.

FRITSCH has registered the following categories according to the German electrical and electronic equipment act, section 6, paragraph 1, clause 1 and section 17, paragraphs 1 and 2:

**Mills and devices for the preparation of samples have been registered under category 6 for electrical and electronic tools (except for large stationary industrial tools).**

**Analytical devices have been registered under category 9, monitoring and control instruments.**

It has been accepted that FRITSCH is operating only in the business-to-business area. The German registration number for FRITSCH is WEEE reg. no. DE 60198769

### **FRITSCH WEEE coverage**

Since the registration of FRITSCH is classified for bilateral transactions, no legal recycling or disposal process is described. FRITSCH is not obliged to take back used FRITSCH devices.

FRITSCH declares it is prepared to take back used FRITSCH devices for recycling or disposal free of charge whenever a new device is purchased. The used FRITSCH device must be delivered free of charge to a FRITSCH establishment.

In all other cases FRITSCH takes back used FRITSCH devices for recycling or disposal only against payment.

## 11 Guarantee terms

### Guarantee period

As manufacturer, FRITSCH GmbH provides – above and beyond any guarantee claims against the seller – a guaranty valid for the duration of two years from the date of issue of the guarantee certificate supplied with the device.

Within this guarantee period, we shall remedy all deficiencies due to material or manufacturing defects free of charge. Rectification may take the form of either repair or replacement of the device, at our sole discretion. The guarantee may be redeemed in all countries in which this FRITSCH device is sold with our authorisation.

### Conditions for claims against the guarantee

This guarantee is subject to the condition that the device is operated according to the instructions for use / operating manual and its intended use.

Claims against the guarantee must include presentation of the original receipt, stating the date of purchase and name of the dealer, together with the complete device type and serial number.

**For this guarantee to take effect, the answer card entitled "Securing of Guarantee" (enclosed with the device) must be properly filled out and despatched without delay after receipt of the device and be received by us within three weeks or alternatively, *online registration* must be carried out with the above-mentioned information.**

### Reasons for loss of the guarantee

**The guarantee will not be granted in cases where:**

- Damage has arisen due to normal wear and tear, especially for wear parts, such as: Crushing jaws, support walls, grinding bowls, grinding balls, sieve plates, brush strips, grinding sets, grinding disks, rotors, sieve rings, pin inserts, conversion kits, sieve inserts, bottom sieves, grinding inserts, cutting tools, sieve cassettes, sieve and measuring cell glasses.
- Repairs, adaptations or modifications were made to the device by unauthorized persons or companies.
- The device was not used in a laboratory environment and/or has been used in continuous operation.
- Damage is present due to external factors (lightning, water, fire or similar) or improper handling.
- Damage is present that only insubstantially affects the value or proper functioning of the device.
- The device type or serial number on the device has been changed, deleted, removed or in any other way rendered illegible
- The above-mentioned documents have been changed in any way or rendered illegible.

### Costs not covered by the guarantee

This guarantee excludes any costs for transport, packaging or travel that accrue in the event the product must be sent to us or in the event that one of our specialist technicians is required to come to your site. Any servicing done by persons not authorised by us and any use of parts that are not original FRITSCH accessories and spare parts will void the guarantee.

### Further information about the guarantee

The guarantee period will neither extend nor will a new period of guarantee begin in the event that a claim is placed against the guarantee.

Please provide a detailed description of the type of error or the complaint. If no error description is enclosed, we shall interpret the shipment as an assignment to remedy all recognisable errors or faults, including those not covered by the guarantee. Errors or faults not covered by the guarantee shall in this case be rectified at cost.

We recommend reading the operating manual before contacting us or your dealer, in order to avoid unnecessary inconvenience.

Ownership of defective parts is transferred to us with the delivery of the replacement part; the defective part shall be returned to us at buyer's expense.

**NOTICE**

Please note that in the event that the device must be returned, the device must be shipped in the original Fritsch packaging. Fritsch GmbH denies all liability for any damage due to improper packaging (packaging not from Fritsch).

Any enquiries must include a reference to the serial number imprinted on the type plate.

## 12 Exclusion of liability

Before using the product, be sure to have read and understood this operating manual.

The use of the product requires technical knowledge; only commercial use is permitted.

The product may be used exclusively within the scope of applications set down in this operating manual and within the framework of guidelines put forth in this operating manual and must be subject to regular maintenance. In case of non-compliance, improper use or improper maintenance, the customer assumes full liability for the functional capability of the product and for damage or injury arising from violating these obligations.

The contents of this operating manual are subject in entirety to copyright law. This operating manual and its contents may not be copied, further distributed or stored in any form, in part or in whole, without the prior written consent of Fritsch.

This operating manual has been prepared to the best of our knowledge and checked for accuracy at the time of printing. FRITSCH GMBH assumes no guarantee or liability whatsoever for the accuracy or completeness of the contents of this operating manual, including but not limited to the implied warranties of merchantability and fitness for a particular purpose, unless liability is expressly prescribed by applicable laws or jurisprudence.

FRITSCH GMBH expressly reserves the right to modify and/or update this operating manual without prior notice. The same applies to modifications and improvements to the products described in this operating manual. It is the responsibility of the user to ensure that they have the current version of this operating manual. For more information, please contact your local FRITSCH GMBH distributor or Fritsch GmbH, Industriestr. 8, D-55473 Idar-Oberstein.

Not all parts shown here are necessarily installed in the product. The buyer is not entitled to delivery of these parts. If interested, please contact your local FRITSCH GMBH distributor or Fritsch GmbH, Industriestr. 8, D-55473 Idar-Oberstein.

FRITSCH GMBH takes the greatest care to ensure that the quality, reliability and safety of your products are continuously improved and adapted to the state of the art. The supplied products as well as this operating manual conform to the current state of the art when they leave the sphere of influence of FRITSCH GMBH.

By using the product the customer agrees with this and recognizes that defects, malfunctions or errors cannot be completely excluded. To prevent risk of damage to persons or property or of other direct or indirect damage, resulting from this or other causes, the customer must implement sufficient and comprehensive safety measures for working with the product.

Fritsch GmbH excludes any liability, warranty, or other obligation to compensate for damages, regardless of whether this liability, warranty, or other obligation is explicit or implicit, contractual or arising from unlawful acts or prescribed contractually, by law, or otherwise. In no event shall the buyer be entitled to any compensation from Fritsch GmbH for any special, direct, indirect, coincidental or consequential damage, including but not limited to lost profits, lost savings, lost sales or financial loss of any kind or for compensation of third parties, for downtimes, for lost goodwill, for damage to or replacement of equipment and property, for costs or restoration of materials or goods related to the product or the use of our products, for other damage or injury to persons (including fatal

injuries) or similar. The above exclusion of liability is limited by mandatory liability as prescribed by laws or jurisprudence. Liability for negligence is excluded in all cases.

No permission is given expressly, implicitly or otherwise for the use of patents, brands or other copyrights. We also assume no liability for copyright infringements or infringements of the rights of third parties arising from the use of this product.

Neither compliance with this operating manual nor the conditions and methods used during installation, operation, use and maintenance of the product can be monitored by Fritsch GmbH. Improper execution of the installation can result in property damage and thus endanger persons. Therefore, we assume absolutely no responsibility or liability for loss, damage or costs that result from errors at installation, improper operation or improper use or improper maintenance or are in any way connected to these.



## 14 Index

<b>A</b>		<b>O</b>	
Accident prevention. . . . .	7	Operating noise. . . . .	13
Ambient conditions. . . . .	16	Operating principle. . . . .	8
Authorised persons. . . . .	7	Overload protection. . . . .	12
<b>B</b>		<b>P</b>	
Basic structure. . . . .	6	Power consumption. . . . .	13
<b>C</b>		Protection against restarting. . . . .	12
Changing the timer settings. . . . .	16	<b>R</b>	
Checklist for troubleshooting. . . . .	28	Repairs. . . . .	28
Clamping the grinding bowls. . . . .	23	Requirements for the user. . . . .	7
Cleaning grinding elements. . . . .	25	<b>S</b>	
Cleaning the mill. . . . .	25	Safety information. . . . .	9
Conducting a grinding operation. . . . .	24	Safety logbook. . . . .	34
Control panel. . . . .	23	Scope of application. . . . .	7
Current consumption. . . . .	13	Selecting the grinding balls. . . . .	18
<b>D</b>		Selecting the grinding bowl. . . . .	18
Dimensions. . . . .	13	Setting the running time. . . . .	24
Disposal. . . . .	29	Setting the vibration frequency. . . . .	23
Dry grinding. . . . .	22	Setting up the device. . . . .	15
<b>E</b>		Skilled workers. . . . .	7
Electrical connection. . . . .	16	Switching off. . . . .	17
Electrical fuses. . . . .	13	<b>U</b>	
Electrical safety. . . . .	12	Unpacking the device. . . . .	15
Exclusion of liability. . . . .	32	<b>V</b>	
Explanation of signs. . . . .	9	Vibration frequency. . . . .	21
Explanation of symbols. . . . .	9	Voltage. . . . .	13
<b>F</b>		<b>W</b>	
Filling grinding bowls. . . . .	19	Warning information. . . . .	9
Final fineness. . . . .	14	WEEE. . . . .	29
Function check. . . . .	17	Weight. . . . .	13
<b>G</b>		Wet grinding. . . . .	22
Grinding duration. . . . .	21, 23		
Guarantee terms. . . . .	30		
<b>H</b>			
Hazardous points. . . . .	12		
<b>I</b>			
Initial start-up. . . . .	17		
Installation. . . . .	15		
<b>M</b>			
Maintenance. . . . .	26		
Materials. . . . .	13		
<b>N</b>			
Number of balls in the grinding bowl. . . . .	19		





© 2014

Fritsch GmbH

Milling and Sizing

Industriestraße 8

D - 55743 Idar-Oberstein

Telephone: +49 6784 70-0

Email: [info@fritsch.de](mailto:info@fritsch.de)

Internet: [www.fritsch.de](http://www.fritsch.de)

---