

Operating instructions

VARIABLE SPEED ROTOR MILL

PULVERISETTE 14 *premium line*

Valid starting with: 14.6020/00001



Read the instructions prior to performing any task!



Fritsch GmbH
Milling and Sizing
Industriestrasse 8
D - 55743 Idar-Oberstein
Telephone: +49 6784 70-0
Email: info@fritsch.de
Internet: www.fritsch.de

Certifications and CE conformity

Certification

Fritsch GmbH has been certified by the SGS-TÜV Saar GmbH.



An audit certified that Fritsch GmbH conforms to the requirements of the DIN EN ISO 9001:2015.

CE Conformity

The enclosed Conformity Declaration lists the guidelines the FRITSCH instrument conforms to, to be able to bear the CE mark.

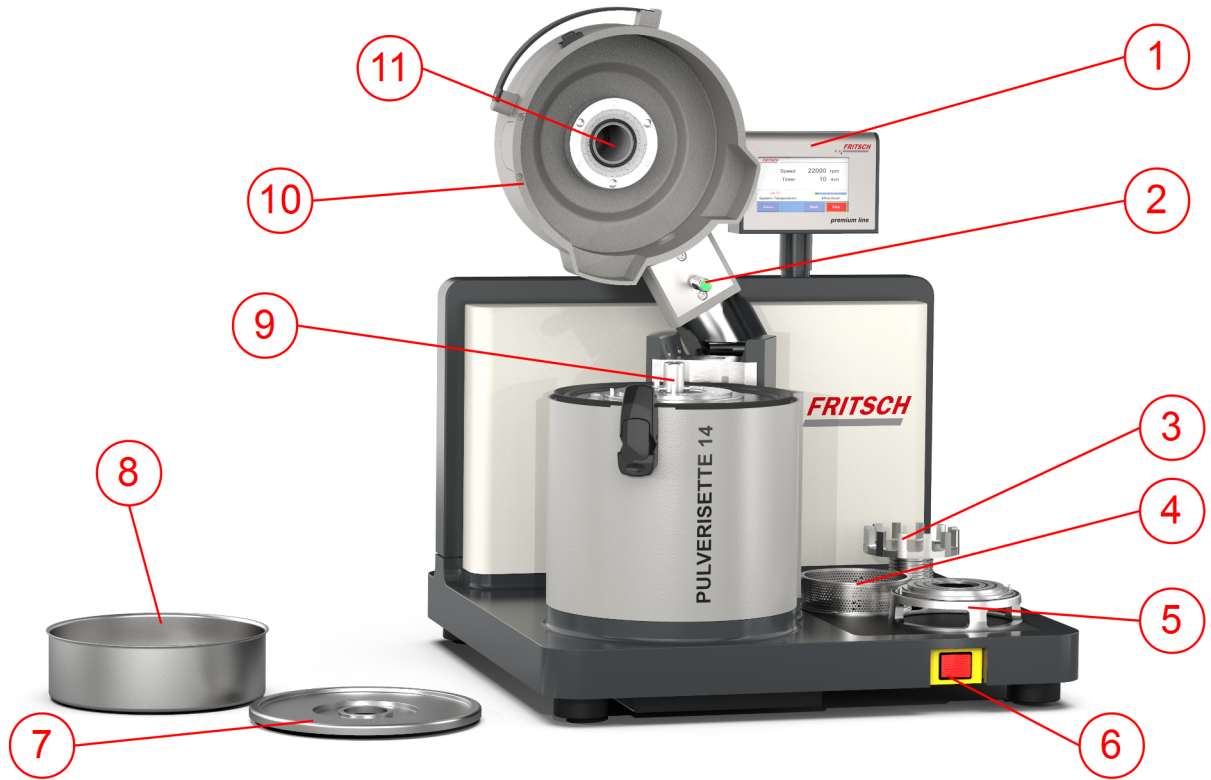

Table of contents

1	Basic structure.	6
2	Safety information and use.	7
	2.1 Requirements for the user.	7
	2.2 Scope of application.	7
	2.2.1 Operating principle.	8
	2.2.2 Speed control.	9
	2.3 Obligations of the operator.	9
	2.4 Information on hazards and symbols used in this manual.	9
	2.5 Device safety information.	12
	2.6 Protective equipment.	13
	2.6.1 Opening the hood without mains connection.	13
	2.7 Hazardous points.	14
	2.8 Electrical safety.	14
	2.8.1 General information.	14
	2.8.2 Protection against restart.	14
	2.8.3 Overload protection.	14
3	Technical data.	15
	3.1 Dimensions.	15
	3.2 Weight.	15
	3.3 Operating noise.	15
	3.4 Voltage.	15
	3.5 Current consumption.	15
	3.6 Power consumption.	15
	3.7 Protection class.	15
	3.8 Electrical fuses.	15
	3.9 Material.	15
	3.10 Final fineness.	16
4	Installation.	17
	4.1 Transport.	17
	4.2 Unpacking.	17
	4.3 Scope of delivery.	17
	4.4 Setting up.	17
	4.5 Ambient conditions.	18
	4.6 Prepare power cord.	19
	4.7 Electrical connection.	22

5	Initial start-up	23
5.1	Switching on	23
5.2	Function check	23
5.3	Standstill	23
6	Using the device	24
6.1	Impact element	25
6.1.1	Impact rotor	25
6.1.2	Sieve ring	26
6.1.3	Inserting the impact element	26
6.2	Cutting insert	28
6.2.1	Cutting rotor	28
6.2.2	Strainer bowls	28
6.2.3	Inserting the cutting insert	29
6.3	Conducting a grinding operation	33
6.4	Removing the grinding elements	33
6.5	Grinding with external cooling	34
6.5.1	External cooling	35
6.6	Grinding with heavy-metal-free or metal-free grinding elements	35
6.7	Continuous feeding of source material	36
6.8	Grinding with the impact bar insert	37
6.9	Factors with an impact on grinding	38
6.10	Control panel	39
7	Accessories	40
7.1	High-performance cyclone separator	40
7.2	Small volume Cyclone separator	42
8	Cleaning	44
8.1	Device	44
8.2	Grinding chamber	44
9	Maintenance	45
9.1	Intake filter	45
10	Repairs	46
11	Disposal	47
12	Guarantee terms	48
13	Exclusion of liability	50
14	Safety logbook	52
15	Index	53

1 Basic structure



- | | | | |
|---|----------------|----|-----------------------|
| 1 | Display | 7 | Collecting vessel lid |
| 2 | Lock pin | 8 | Collecting vessel |
| 3 | Rotor | 9 | Rotor holder |
| 4 | Sieve insert | 10 | Hood |
| 5 | Labyrinth disk | 11 | Funnel |
| 6 | Main switch | | |

2 Safety information and use

2.1 Requirements for the user

This operating manual is intended for persons assigned with operating and monitoring the Fritsch PULVERISETTE 14 premium line. The operating manual and especially its safety instructions are to be observed by all persons working on or with this device. In addition, the applicable rules and regulations for accident prevention at the installation site are to be observed. Always keep the operating manual at the installation site of the PULVERISETTE 14 premium line.

People with health problems or under the influence of medication, drugs, alcohol or exhaustion must not operate this device.

The PULVERISETTE 14 premium line may only be operated by authorised persons and serviced or repaired by trained specialists. All commissioning, maintenance and repair work may only be carried out by technically qualified personnel. Qualified personnel are persons who, because of their education, experience and training as well as their knowledge of relevant standards, regulations, accident prevention guidelines and operating conditions, are authorised by those responsible for the safety of the machine to carry out the required work and are able to recognize and avoid possible hazards as defined for skilled workers in IEC 364.

In order to prevent hazards to users, follow the instructions in this manual.

Malfunctions that impair the safety of persons, the PULVERISETTE 14 premium line or other material property must be rectified immediately. The following information serves both the personal safety of operating personnel as well as the safety of the products described and any devices connected to them: All maintenance and repair work may only be performed by technically qualified personnel.

This operating manual is not a complete technical description. Only the details required for operation and maintaining usability are described.

Fritsch has prepared and reviewed this operating manual with the greatest care. However, no guarantee is made for its completeness or accuracy.

Subject to technical modifications.

2.2 Scope of application



NOTICE

This laboratory instrument is designed for an 8-hour shift operation at 30 % duty cycle and not for continuous operation.

The duty cycle is defined as the ratio of load duration to run time. The run time is defined as load duration plus pause time. According to DIN EN 60034-1 (VDE 0530, IEC34-1) a continuous operation already takes place after a standardised run time of 10 minutes. At 30 % duty cycle (DC = ratio of load duration to run time) a load duration of 3 minutes and a pause time of 7 minutes would be within standard.

If the standardised run time of 10 minutes is exceeded, then, by definition, there would be a continuous operation and disproportionate temperature increases may occur, possibly involving increased wear.

Safety information and use



NOTICE

The PULVERISETTE 14 premium line has been built according to the state of the art and in accordance with recognized safety rules. During operation, however, hazards can arise for users or third parties and damage to the machine or other material property can occur.

The PULVERISETTE 14 premium line allows the fast comminution of soft to medium-hard samples, such as:

Plants	Wood	Roots	Leaves	Needles	Spices
Pharmaceuticals	Dragées	Pills	Textiles	Leather	
Chemicals	Fertilizer	Food	Grains	Feed pellets	Plastics
Pulp	Filler	Chalk	Kaolin	Coal	

After embrittlement with liquid nitrogen:

Synthetic resins	Foils	Plastics (PVC, PP, PE)
------------------	-------	------------------------

The extremely high-speed PULVERISETTE 14 premium line enables the comminution of temperature-sensitive ductile or plastic samples. By simultaneously adding liquid nitrogen, samples that are extremely difficult to mill, such as soft PVC foils, can be made fine enough for analysis.

For iron-free grinding, the rotor and sieve used are made of titanium. The inside of the mill, typically made of chrome-nickel stainless steel, has been suitably coated with a relatively abrasion-resistant PTFE layer. The grinding insert made of pure titanium is only for use with "soft materials". Hard substances destroy the sieve ring and drastically reduce the service life of the rotor.

2.2.1 Operating principle

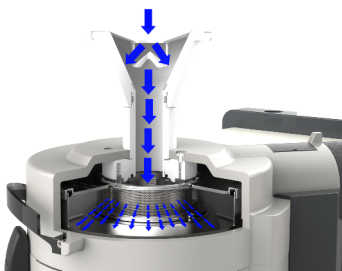

The fast comminution capability of the PULVERISETTE 14 premium line is due to the extremely high speed of the rotor, which is made of stainless, hardened steel. With a circumferential speed of up to 111 m sec^{-1} , the impact energy lies in the range of pin mills, known for their high grinding capacity. Additionally, the sharp-edged teeth of the rotor work in combination with the installed sieve to grind the sample by shearing - similar to high speed cutting mills. After passing through the sieve, the ground sample is collected in a stainless collecting vessel.

The grinding stock is fed through a funnel into the grinding chamber and accelerated outwards radially by the high speed of the rotor. There, the material is caught by the impact rotor, ground, and then discharged through the sieve ring into the collecting vessel at a defined particle feed size.

To ensure continuous flow of the sample, the vibratory feeder LABORETTE 24 is connected to the PULVERISETTE 14 premium line and the free end of the channel is placed over the input funnel of the PULVERISETTE 14 premium line. Depending on the model, the feed rate can be regulated by the mill to always feed the right amount of sample quantity for optimal comminution. If the supply of the grinding stock is too great, the vibration feeder is automatically decelerated.

2.2.2 Speed control

By tapping the number field in the "Speed" menu item, the rotational speed can be preset to between 6000 - 22000 rpm in increments of 1000, and in this way be optimally adapted to the requirements of the grinding of the samples. The speed is readjusted for each load.

2.3 Obligations of the operator

Before using the PULVERISETTE 14 premium line, this manual is to be carefully read and understood. The use of the PULVERISETTE 14 premium line requires technical knowledge; only commercial use is permitted.

The operating personnel must be familiar with the content of the operating manual. For this reason, it is very important that these persons actually receive the present operating manual. Ensure that the operating manual is always near the device.

The PULVERISETTE 14 premium line may exclusively be used within the scope of applications set down in this manual and within the framework of guidelines put forth in this manual. In case of non-compliance or improper use, the customer assumes full liability for the functional capability of the PULVERISETTE 14 premium line and for any damage or injury arising from failure to fulfil this obligation.

By using the PULVERISETTE 14 premium line the customer agrees with this and recognizes that defects, malfunctions or errors cannot be completely excluded. To prevent risk of damage to persons or property or of other direct or indirect damage, resulting from this or other causes, the customer must implement sufficient and comprehensive safety measures for working with the PULVERISETTE 14 premium line.

Neither compliance with this manual nor the conditions and methods used during installation, operation, use and maintenance of the PULVERISETTE 14 premium line can be monitored by Fritsch GmbH. Improper execution of the installation can result in property damage and thus endanger persons. Therefore, we assume absolutely no responsibility or liability for loss, damage or costs that result from errors at installation, improper operation or improper use or improper maintenance or are in any way connected to these.

The applicable accident prevention guidelines must be complied with.

Generally applicable legal and other obligatory regulations regarding environmental protection must be observed.

2.4 Information on hazards and symbols used in this manual

Safety information

Safety information in this manual is designated by symbols. Safety information is introduced by keywords that express the extent of the hazard.



DANGER

This symbol and keyword combination points out a directly hazardous situation that can result in death or serious injury if not avoided.

Safety information and use



WARNING

This symbol and keyword combination points out a possibly hazardous situation that can result in death or serious injury if not avoided.



CAUTION

This symbol and keyword combination points out a possibly hazardous situation that can result in slight or minor injury if not avoided.



NOTICE

This symbol and keyword combination points out a possibly hazardous situation that can result in property damage if not avoided.

Special safety information

To call attention to specific hazards, the following symbols are used in the safety information:



⚠ DANGER

This symbol and keyword combination points out a directly hazardous situation due to electrical current. Ignoring information with this designation will result in serious or fatal injury.



⚠ DANGER

This symbol and keyword combination designates contents and instructions for proper use of the machine in explosive areas or with explosive substances. Ignoring information with this designation will result in serious or fatal injury.



⚠ DANGER

This symbol and keyword combination designates contents and instructions for proper use of the machine with combustible substances. Ignoring information with this designation will result in serious or fatal injury.



⚠ WARNING

This symbol and keyword combination points out a directly hazardous situation due to movable parts. Ignoring information with this designation can result in hand injuries.



WARNING

This symbol and keyword combination points out a directly hazardous situation due to hot surfaces. Ignoring information with this designation can result in serious burn injuries due to skin contact with hot surfaces.

Safety information in the procedure instructions

Safety information can refer to specific, individual procedure instructions. Such safety information is embedded in the procedure instructions so that the text can be read without interruption as the procedure is being carried out. The keywords described above are used.

Example:

1. → Loosen screw.

2. →



CAUTION

Risk of entrapment at the lid.

Close the lid carefully.

3. → Tighten screw.





Tips and recommendations



This symbol emphasises useful tips and recommendations as well as information for efficient operation without malfunction.

Further designations

To emphasise procedure instructions, results, lists, references and other elements, the following designations are used in this manual:

Designation	Explanation
 1., 2., 3. ...	Step-by-step procedure instructions
	Results of steps in the procedure
	References to sections in this manual and relevant documentation
	Lists without a specific order
[Button]	Operating elements (e.g. push button, switch), display elements (e.g. signal lamps)
'Display'	Screen elements (e.g. buttons, function key assignment)

2.5 Device safety information

Please observe!

- Only use original accessories and original spare parts. Failure to observe this instruction can compromise the safety of the machine.
- Accident-proof conduct is to be strictly followed during all work.
- Comply with all currently applicable national and international accident prevention guidelines.



CAUTION

Wear hearing protection!

If a noise level of 85 dB(A) is reached or exceeded, ear protection should be worn to prevent hearing damage.



WARNING

The maximum accepted concentration (MAC) levels of the relevant safety guidelines must be observed; if necessary, ventilation must be provided or the machine must be operated under an extractor hood.



DANGER

Explosion hazard!

- When Comminution oxidizable substances, e.g. metals or coal, there is a risk of spontaneous combustion (dust explosion) if the share of fine particles exceeds a certain percentage. When Comminution these kinds of substances, special safety measures must be taken and the work must be supervised from a specialist.
- The PULVERISETTE 14 premium line is not explosion protected and is not designed to grind explosive materials.

- Do not remove the information signs.



NOTICE

Immediately replace damaged or illegible information signs.

- Unauthorised alteration of the PULVERISETTE 14 premium line will void Fritsch's declaration of conformity to European directives and void the guarantee.
- Only use the PULVERISETTE 14 premium line when it is in proper working order, as intended and in a safety- and hazard-conscious manner adhering to the operating manual. In particular, immediately rectify any malfunctions that could pose a safety hazard.
- If, after reading the operating manual, there are still questions or problems, please do not hesitate to contact our specialised personnel.

2.6 Protective equipment



Protective equipment is to be used as intended and may not be disabled or removed.

All protective equipment is to be regularly checked for integrity and proper functioning.

For start-up, the housing cover (10) has to be closed.

The housing cover is locked during operation.

The mill does not start up if:

- no labyrinth disk has been inserted
- no collecting vessel has been inserted
- the collecting vessel is not covered with a lid.

The temperature at the labyrinth disk is monitored in the grinding chamber. If the disc is heated above 80 °C, the PULVERISETTE 14 *premium line* switches off automatically.



The hood can only be opened when the mill's drive is at standstill.

2.6.1 Opening the hood without mains connection



CAUTION

The emergency release must not be activated while the machine is running! Disconnect the machine from the mains before the emergency release. Failure to observe this will render void the guarantee, and releases us from liability for any resulting damage to the device or personal injury.

2 persons are required for unlocking the PULVERISETTE 14 premium line:

1. ➤ Lift up the back of the device.
2. ➤ Underneath the machine you will see a wire loop in the centre of the base leading into the device's interior.
3. ➤ Use an Allen key to pull at the wire with a certain amount of force.
4. ➤ The lock of the hood is released and it can now be opened manually.
5. ➤ Put down the device. The emergency release will be reset automatically during the next locking cycle.



2.7 Hazardous points



WARNING

- Crushing hazard when closing the housing cover!
- Crushing hazard when removing and positioning the collecting vessel!
- The collecting vessel can become very hot!
- Never operate the device without a sieve ring.
- Cutting hazard at the grinding elements such as rotors, sieves and collecting vessel. These can have sharp edges. Sieves with reinforced edges are used to avoid this hazard. These do not have any sharp metal edges.
- When grinding electrically conductive substances, the fine dust can be suctioned through the filter on the back side of the device and cause short circuits. Therefore, when grinding such substances, work must be carried out especially carefully and cleanly.

2.8 Electrical safety

2.8.1 General information

- The main switch separates the PULVERISETTE 14 premium line from the mains on two poles.
- Switch off the main switch if the PULVERISETTE 14 premium line is idle for a longer period of time (e.g. overnight).

2.8.2 Protection against restart

In case of power failure during operation or after switching off with the main switch, the housing cover is locked. The lock of the housing cover is opened when the power returns. For safety reasons, however, the PULVERISETTE 14 premium line does not restart.

2.8.3 Overload protection

The power consumption is permanently monitored. The monitor switches off the motor after a continuous overload. To rectify the malfunction, switch off the PULVERISETTE 14 premium line and remove the blockage. Afterwards, switch the device back on and start the motor by pressing the [START] button.

The device switches off if the drive motor becomes too hot.

The PULVERISETTE 14 premium line switches off when the drive is blocked (→ Chapter 10 'Repairs' on page 46).

3 Technical data

3.1 Dimensions

520 x 630 x 550 mm (width x height x depth)

3.2 Weight

Weight: 44 kg (net)

3.3 Operating noise

Operation condition of device during measurement: 0.2 mm sieve ring, 12-rib steel rotor with max. speed (22000 rpm), source material: Rice.

- Workplace-specific emission value L_{pA} : 75.9 dB(A)

3.4 Voltage

- Device (14.6020.00): 200 - 240 V/1~

Transient overvoltages in accordance with overvoltage category II are permitted.

3.5 Current consumption

The maximum current consumption briefly reaches approx. 10.9 A (14.6020.00).

3.6 Power consumption

Depending on the load, the PULVERISETTE 14 *premium line* will reach a power consumption of approx. 2.5 kW.

3.7 Protection class

IP 22

3.8 Electrical fuses

Fuse on the back of device:

2 x 15 AT

1 x 2.5 AT

3.9 Material

- Maximum feeding size approx. 15 mm
- Maximum feed quantity when using the pan 200 ml
- Maximum feed quantity when using the cyclone separator 60 ml

3.10 Final fineness

The achievable final fineness depends largely on the sample properties and the grinding element used.

4 Installation

4.1 Transport

The device is delivered on a transport pallet with a wooden cover. We recommend using a forklift or pallet truck for transporting the packed device.



DANGER

Do not step under the transport pallet during transport.



WARNING

Improper lifting can lead to personal injury or property damage. The machine is only to be lifted with suitable equipment and by qualified personnel.

The guarantee excludes all claims for damage due to improper transport.

4.2 Unpacking

- Pull out the 4 nails that fasten the lid to the surrounding packaging.
- Remove the lid.
- Take out the accessories and the foam parts.
- Then lift the device out of the wooden crate.
- Compare the contents of your delivery with your order.



Please store the transport packaging so that it can be reused if you need to return the product. Fritsch GmbH accepts no liability for damage caused by improper packaging (packaging that is not from Fritsch).

4.3 Scope of delivery

- Inner funnel made of stainless steel 316L (14.4297.10)
- Funnel cover (14.4293.16)
- Power cable

4.4 Setting up



NOTICE

Allow the device to acclimatise for two hours before commissioning. High temperature differences can lead to condensation in the device and damage to the electronics after switching on.

Installation

Strong temperature fluctuations can occur during transport or interim storage. Depending on the temperature difference between the installation site and the transport or storage environment, condensation can form inside the device. This can damage the electronics if the devices are switched on too early. Wait for at least two hours after setup before switching on the device.



DANGER

Do not step under the transport pallet during transport.



WARNING

Crushing hazard!

Always lift with 2 persons.

Hold the bottom edge of the housing when lifting.



NOTICE

Never operate PULVERISETTE 14 premium line while it is standing on the transport pallet!



NOTICE

Make sure the air outlet on the rear ventilation grate is not obstructed. Risk of overheating!

Place the PULVERISETTE 14 premium line on a flat, stable surface. It does not have to be fastened to this surface. The rubber feet on the PULVERISETTE 14 premium line can be adjusted to compensate for uneven surfaces.

- Make sure that the PULVERISETTE 14 premium line is easily accessible.

4.5 Ambient conditions



WARNING

Mains voltage

- The device may only be operated indoors.
- The surrounding air must not contain any electrically conductive particles.
- Maximum relative humidity 80% for temperatures up to 31 °C, linearly decreasing down to 50% relative humidity at 40 °C.

- The room temperature should be between 5 and 40 °C.
- Altitudes up to 2000 m
- Degree of pollution 2 according to IEC 60664-1:2007.

4.6 Prepare power cord



⚠ DANGER

Changes to the connection line may only be made by a qualified person.

The Variable speed rotor mill requires a mains power supply with 200 - 240 V at a mains frequency of 50 - 60 Hz for proper operation. Prepare the power cable as follows:

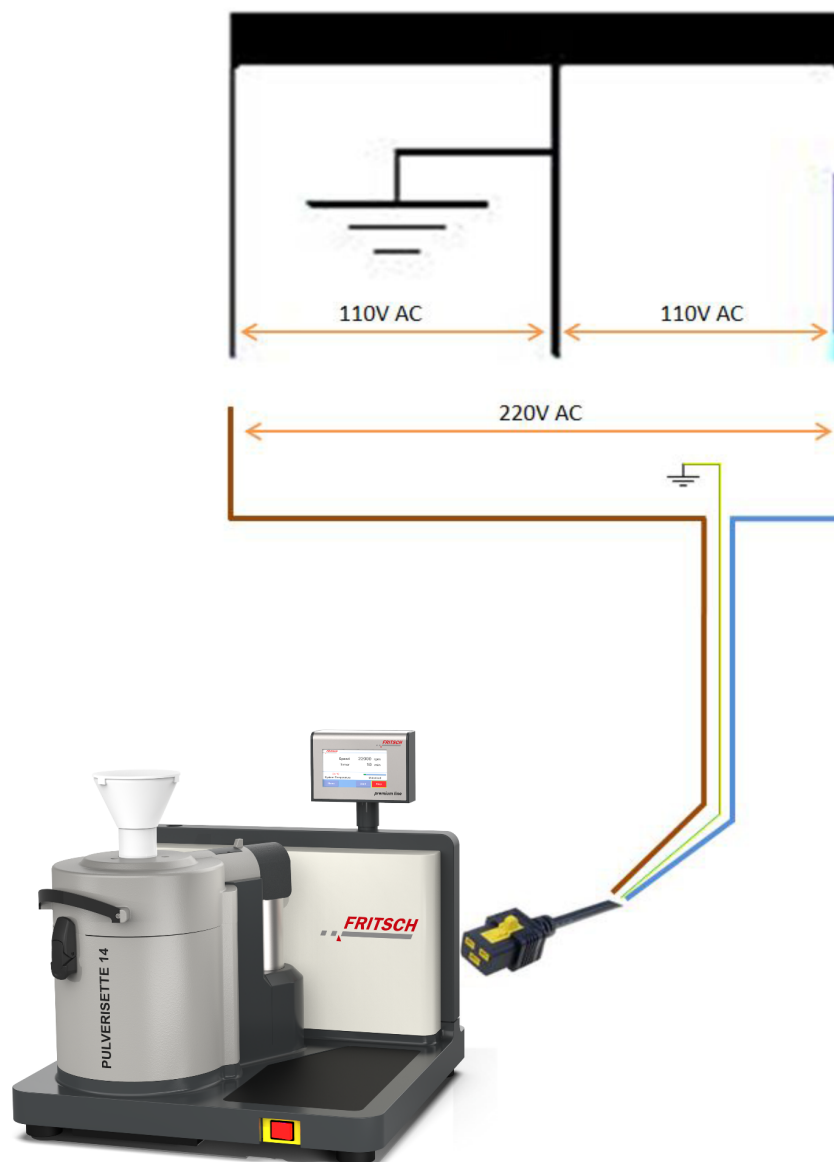

Fig. 1: 1 phase, 3 wires 120 / 240 V earthed midpoint

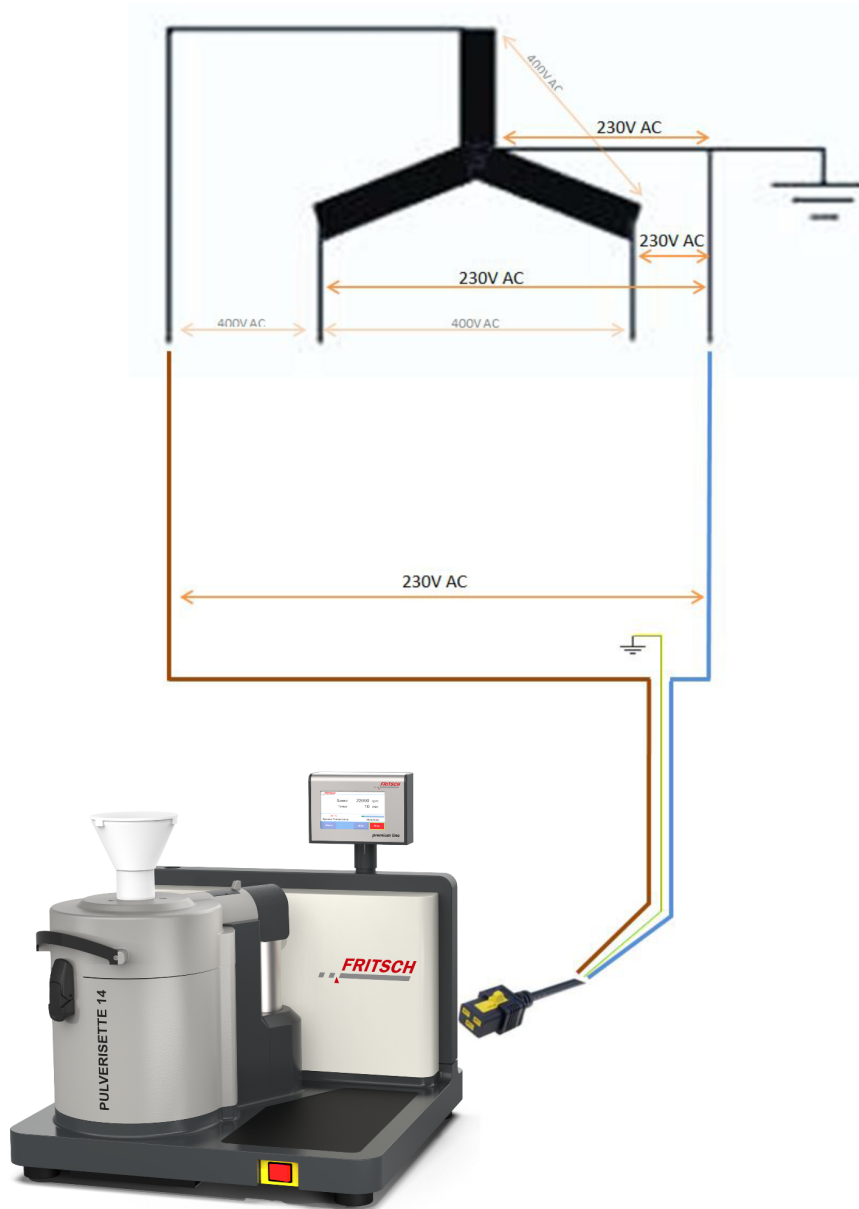

Fig. 2: 3 phases, 4 wires earthed 230 / 400 V

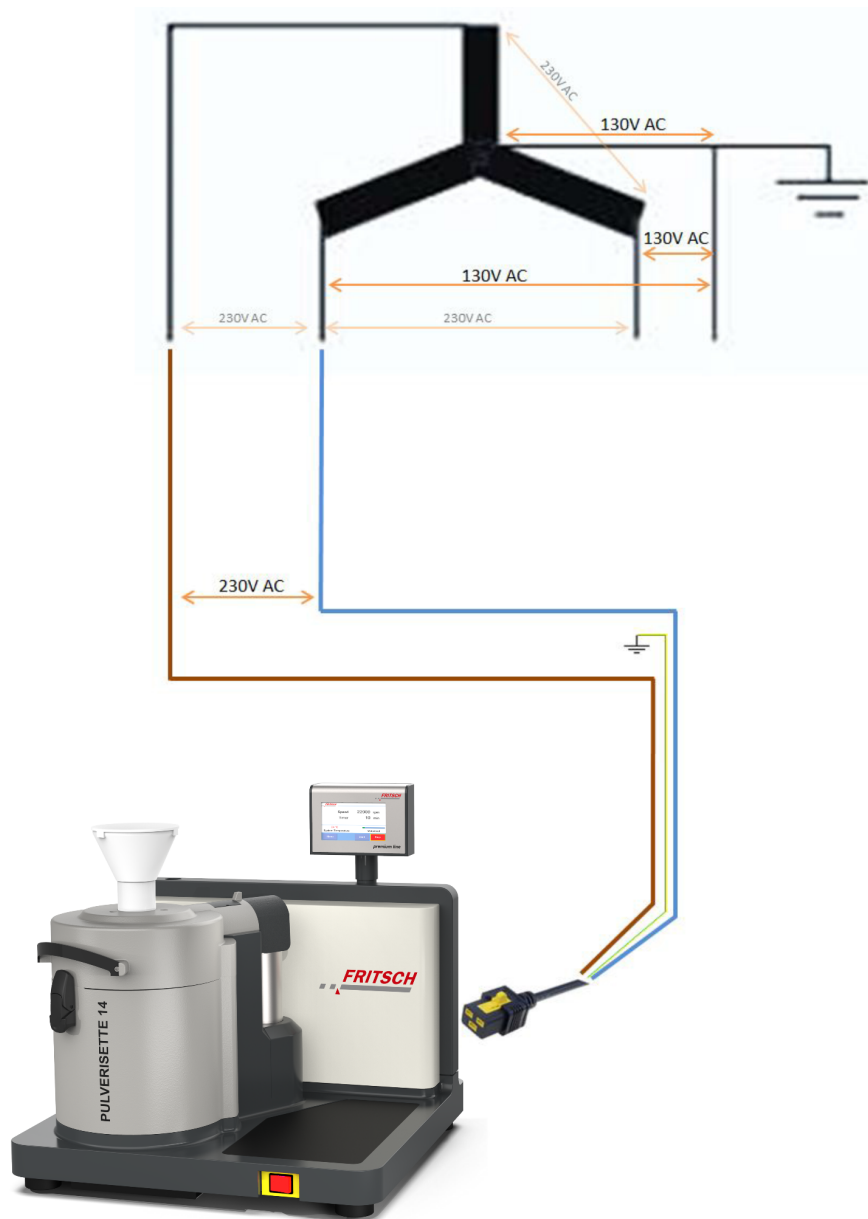

Fig. 3: 3 phases, 4 wires earthed 130 / 230 V



If you have a question, please contact our technical service.
E-Mail: schmell@fritsch.de or telephone: +49 6784 70279.

4.7 Electrical connection



DANGER

Provide short-circuit protection!

Risk of damage due to short-circuits.

- Make sure that the socket is connected to a mains line protected with a residual current circuit breaker.



DANGER

Mains voltage!

Changes to the connection line may only be made by a qualified person.



CAUTION

Ignoring the values on the type plate may result in damage to the electrical and mechanical components.

- Check the device voltage with the values of the mains grid before connecting the PULVERISETTE 14 premium line.
- Plug the supplied power cable into the respective socket (Mains) on the back side of the device.
- Afterwards, connect the power cable of the PULVERISETTE 14 premium line to the electrical outlet.
- 200 - 240 V single-phase alternating current and 200 - 230 V three-phase alternating current with protective conductor, fuse max. 15 A
- If you connect a switchbox (86.5500.00) and exhaust systems to each of the two 'Exhauster' connections, then they will be switched on directly as well at the start of a comminution. The dust exhaust system connected to the 'Exhauster Cyclone' connection can also be manually switched on separately in the menu for exhausting after a comminution.



NOTICE

Fritsch mills are speed controlled. The devices are equipped for this with frequency converters. In order to comply with the EMC directive, many measures must be taken to prevent operational transient emissions.

The possible leakage currents resulting from filtering measures can trigger a conventional residual current circuit breaker in the mains line. **This is no defect!**

To prevent this, special residual current circuit breakers, which are adapted for operation with frequency converters, are commercially available.

Operation without a residual current switch is possible, but must be done in accordance with the relevant regulations.

5 Initial start-up

Perform initial start-up only after all work as described in [Chapter 4 'Installation'](#) on page 17 has been carried out.

5.1 Switching on

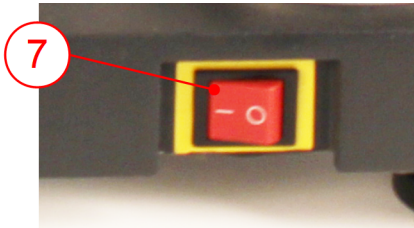

- Connect the device to the mains.
- Switch on the device with the main switch (7) on the front of the device.
- The display lights up.

5.2 Function check



CAUTION

Only conduct the function check at a speed of 6000 1/min.

- Open the housing cover.
- Insert labyrinth disk, collecting vessel, rotor, sieve insert and lid of the collecting vessel.
- Close the lid again.
- On the control panel, set the speed to 6000 rpm and press *[START]*.
- The housing cover is locked electrically and the mill runs at the preselected speed.

5.3 Standstill

- Press *[STOP]* on the control panel.
- After a short time, once the mill is at standstill, the housing cover is unlocked and can be opened.

6 Using the device



WARNING

If the grinding elements used are not original accessories, we assume no guarantee and exclude all liability for damage to the device or for personal injury.



WARNING

Make certain before starting the machine that the grinding elements have been properly installed and locked in place and that there are not any loose parts inside of the device.

Failure to observe this provision will void the guarantee and releases us from liability for any resulting damage to the machine or personal injury.



WARNING

Wear safety gloves!

The collecting vessel and the grinding elements can become very hot after grinding. Grinding elements such as rotors, sieves and the collecting vessel can have sharp edges. For cleaning wear gloves that are safe and without defect.

To avoid cutting hazards from sieve rings, use sieves with reinforced edges as standard. These do not have any sharp metal edges.



CAUTION

When grinding electrically conductive substances, the fine dust can be suctioned through the filter on the back side of the device and cause short circuits. Therefore, when grinding such substances, work must be carried out especially carefully and cleanly.



CAUTION

The device may not be run unsupervised.



NOTICE

Risk of overheating!

Due to the operating principle, the PULVERISETTE 14 premium line heats up even when idling. The temperature is monitored by a safety device at the labyrinth disk and switches the device off when 80 °C has been reached. For continual comminution, plan regular breaks to allow the system to cool down and to clean it.



NOTICE

Risk of melting!

Feed material with unknown properties or material with a low melting point to the device in small quantities. After test grinding, check the grinding elements for melting. If this is the case, the comminution material must be "embrittled" before grinding with the PULVERISETTE 14. To do this, embrittle the material for a few minutes using liquid nitrogen and then feed it to the device.

6.1 Impact element

6.1.1 Impact rotor

6-rib rotor

The rotor with 6 ribs enables fast fine grinding for materials with a particle feed size < 10 mm (maximum length < 15 mm) or fibrous material. (Order no. 14.4330.10 for stainless steel; Order no. 14.4430.32 for pure titanium)

12-rib rotor

The rotor with 12 ribs enables fast fine grinding for materials with a particle feed size < 10 mm (largest length).

(Order no. 14.4334.10 for stainless steel; Order no. 14.4434.32 pure titanium; Order no. 14.4335.10 stainless steel 316L)

These rotors are also suitable for pre-crushing or rough comminution.

24-rib rotor

The rotor with 24 ribs enables fast fine grinding for various specific materials with a particle feed size < 5 mm (largest length).

(Order no. 14.4337.10 for stainless steel; Order no. 14.4437.32 for pure titanium)



NOTICE

The 24-rib rotor should not be used for grinding plastics containing carbon or glass fibres. There is a risk of breaking a tooth.

When using the cyclone separator (14.4800.00), this rotor achieves the highest air flow rate. By doing so, it accelerates grinding, improves cooling and helps to protect heat-sensitive grinding stock.



NOTICE

When the rotors are badly worn, there is a risk of the teeth breaking off and causing further damage to the device.

→ Replace worn rotors in good time!



Using the device

6.1.2 Sieve ring

The final fineness of the source material is determined by the choice of sieve ring.

For the sieve ring sizes available, see the service manual.

Typically, the final fineness of the source material is smaller than the perforation diameter set by the sieve ring. In **normal cases**, use the **sieve ring with trapezoidal perforation** with the **direction arrow on it pointing upwards ↑**.

With this setting, some particles in the source material may be longer than as specified by the perforation diameter.

If a **large share of fine particles is desired**, install the sieve ring with the **direction arrow pointed downwards ↓**. This lowers the throughput.



NOTICE

Grinding unsuitable sample material can damage the sieve rings.

Examples of unsuitable samples:

- Tough or hard-tough samples
- Samples larger than the distance between the rotor teeth.

These samples can get stuck between the rotor and the sieve and destroy the sieve.

Grinding tools are not covered by the warranty terms of FRITSCH GmbH!

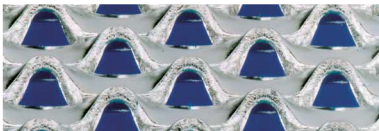

Sieve rings with trapezoidal perforation, available as original accessories from Fritsch, can have manufacturing sieve opening tolerances of up to +/- 20% of the nominal mesh width.

6.1.3 Inserting the impact element

The grinding elements are to be installed in the PULVERISETTE 14 premium line as described in the following:

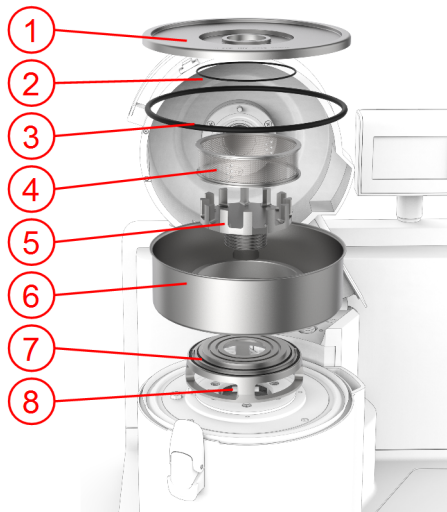

1. Carefully set the labyrinth disk (7) over the motor mounting flange (8) until it lies flush on the motor mounting flange (8). For this, pay attention to the temperature sensor – it must fit into the bore hole on the underside of the labyrinth disk. In addition, it is positioned by a cylinder pin on the left-hand side.
2. Set the collecting vessel (6) onto the labyrinth disk (7). Make sure that the O-rings are seated correctly in the corresponding grooves of the labyrinth disk (7).
3. Insert the rotor (5) through the labyrinth disk onto the motor shaft. The cut grooves on the bottom end of the rotor shaft have to point in the direction of the flattened sides of the motor shaft. The rotor is guided by a cylinder pin.



CAUTION

Do not force on the rotor (5) when placing it on the motor shaft.

It should glide easily onto the motor shaft and after being placed on the shaft, it should easily be turned by the cylinder pin to the left and right up to the stops (apply some oil, if necessary).

4. Slide the sieve ring (4) over the rotor (5) and place it on the O-ring of the labyrinth disk.



When inserting the sieve ring, rotate it until it slides into the two cylinder pins of the labyrinth disc.

5. Seal closed the collecting vessel (6) using the lid (1) and lid seal (3). The centring shoulder with the O-ring (2) in the centre of the lid has to be centred on the sieve ring (4).
6. Lock the housing cover. By locking the PULVERISETTE 14 premium line, the grinding elements are clamped into place for grinding.



CAUTION

The PULVERISETTE 14 premium line may only be operated when all parts are in place.

Using the device

6.2 Cutting insert

6.2.1 Cutting rotor

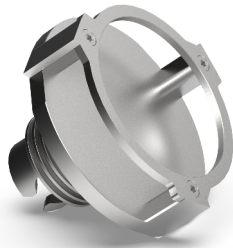

The cutting rotor with cooling fins is equipped with 3 rotor blades. These are available as hardened, stainless steel (14.6590.00) and as tungsten carbide (14.6595.00).

For use in heavy metal and iron-free grinding, the cutting rotor is available with rotor blades and fixed knives also made of titanium (14.4690.00) and zirconium oxide (14.6595.00).

6.2.2 Strainer bowls

There are 4 fixed knives and 4 sieve inserts in the strainer bowls. They have to be removed and adjusted as follows.

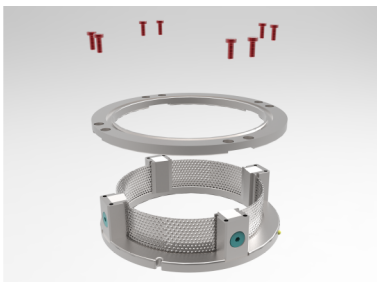

1. ➤ Loosen the 8 cylinder screws on the top.
2. ➤ The upper ring can now be removed.

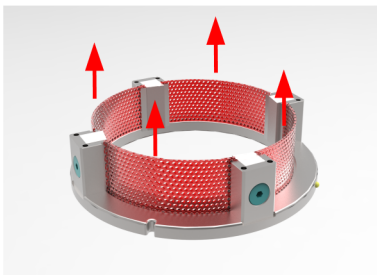

3. ➤ Then remove the sieves.

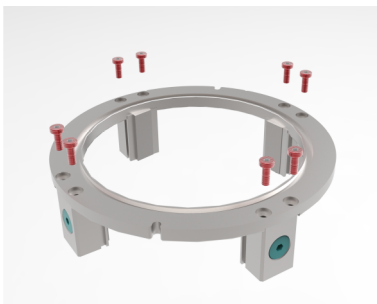

4. ➤ Loosen the 8 cylinder screws on the bottom.
5. ➤ Remove the 4 knife holders with the fixed knives.

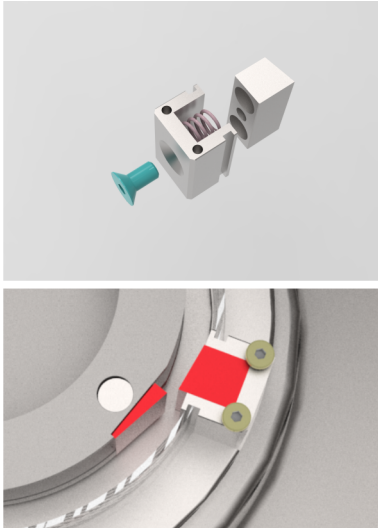

6. The fixed knives can be removed using a Torx 20 key.



When unscrewing the fixed knives, be aware that they are under spring pressure and can shoot out when loosening the screws.



When reinstalling the knives, always observe the direction of rotation of the rotor.

6.2.3 Inserting the cutting insert

Design of the cutting insert:

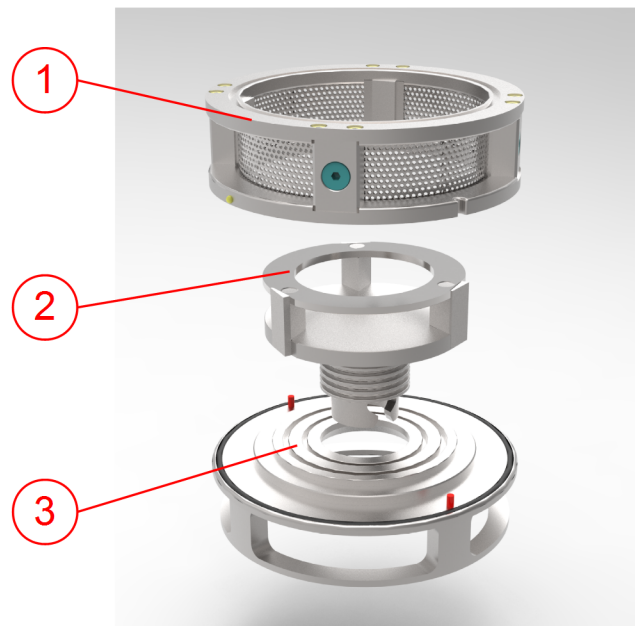

- 1 Sieve support with 4 fixed knives and 4 sieve inserts
- 2 Cutting rotor with 3 rotor knives
- 3 Labyrinth disk with special detection magnet



When the cutting insert is used, the speed is minimized to max. 18.000 rpm.

Using the device



We recommend the use of a high-performance cyclone in combination with an extraction system. This provides a better and quicker throughput and cools the system.

To use the PULVERISETTE 14 premium line as a cutting mill, the accessories must be installed as follows:

1. Position the special labyrinth disk in the grinding chamber.

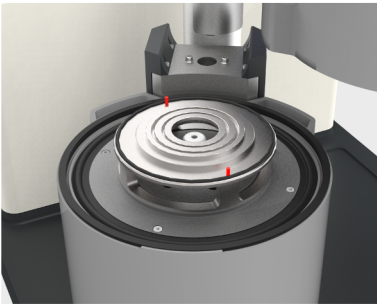

2. Fit the sieve support with the 4 fixed knives and 4 sieve segments on the labyrinth disk. The grooves on the sieve support must fit into the pins of the labyrinth disk.

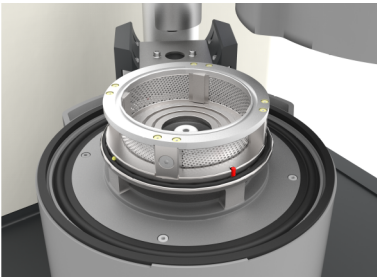

3. Position the collecting vessel while also observing the grooves and notches on the sieve support.

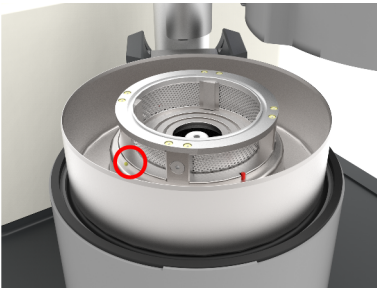

4. Place the cutting rotor on the motor shaft.

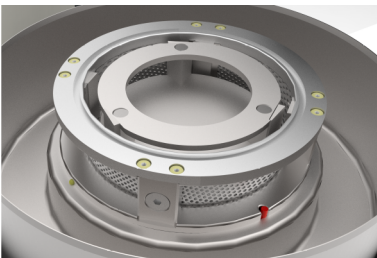

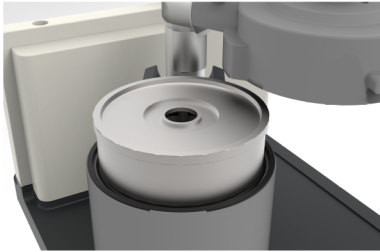

5. → Then place the lid on the collecting vessel and close the grinding chamber via the touch screen. Continue with → *Chapter 6.3 'Conducting a grinding operation' on page 33.*

6.2.3.1 Setting the gap width of the knives



Also watch the corresponding video on YouTube: → [Click here!](#)

To set the gap width between the fixed knives and the moving knives, proceed as follows:

1. → Loosen the 8 screws on the upper ring of the sieve support.



2. → Check that the fixed knives can be moved in the spring suspension. If the knives cannot be moved, loosen the 8 screws further.

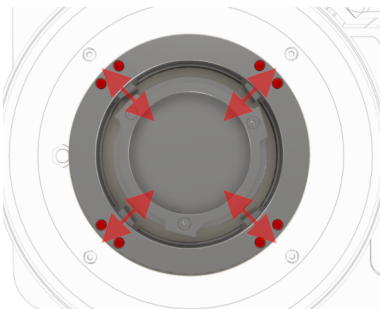

Using the device

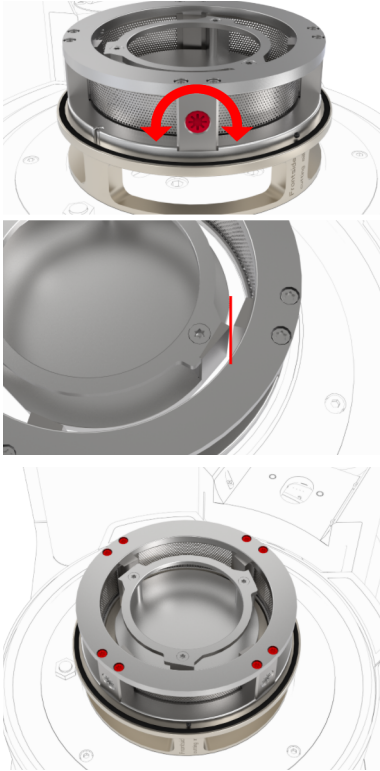

3. Turn the screws on the individual fixed knives clockwise using a Torx 20 key – the knives are moved outwards against the springs and the gap increases. When turning anticlockwise, the springs will push the knives inwards and the gap decreases.



Measure the set gap using a feeler gauge. The gap must always be larger than 0.1 mm.

By manually turning the rotor you can check the gap of all 4 fixed knives against the 3 rotor knives.

4. Once the gap width has been correctly set, the 8 screws on top have to be retightened firmly to lock the fixed knives in place.

6.2.3.2 Removing the rotor knives



1. Loosen the 3 screws using a Torx 15 key.
2. Lift off the upper ring with the 3 screws and remove the knives.



When reinstalling the knives, the long part must point downwards.

6.3 Conducting a grinding operation



CAUTION

Wear hearing protection!

Hearing protection should be worn when grinding, because noise levels can reach or exceed 75.9 dB(A).

After closing the PULVERISETTE 14 premium line as described in [Chapter 5.2 'Function check'](#) on page 23, you can start grinding:

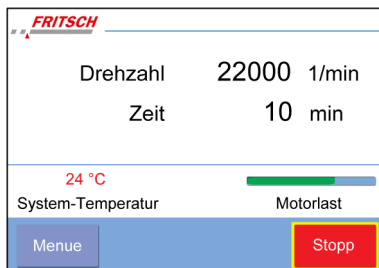
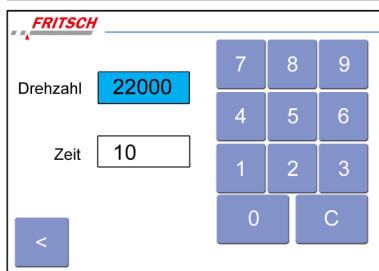
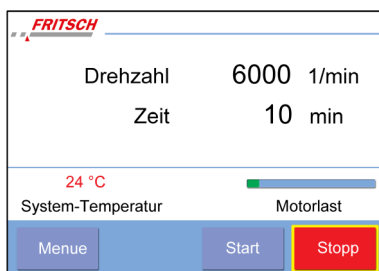

1. ➤ Switch on the PULVERISETTE 14 premium line by the main switch on the front.
2. ➤ By tapping on the *[Speed]* button, the Parameters window opens.
3. ➤ Enter the desired speed and duration for the grinding process.
4. ➤ Press the Back button *[<]* to return to the main screen.
5. ➤ After pressing the *[Start]* button, the grinding chamber is locked and the PULVERISETTE 14 premium line starts up.
6. ➤ Wait until the mill has ramped up to the set speed.
7. ➤ Fill small amounts of the grinding stock into the inner funnel.
8. ➤ At the end of the grinding process press the *[Stop]* button or wait until the set time has expired.
9. ➤ Once the motor has come to a standstill, open the hood and remove the grinding elements.

6.4 Removing the grinding elements



WARNING

Wear safety gloves!

The collecting vessel and the grinding elements can become very hot after grinding. Grinding elements such as rotors, sieves and the collecting vessel can have sharp edges. For cleaning wear gloves that are safe and without defect.

To avoid cutting hazards from sieve rings, use sieves with reinforced edges as standard. These do not have any sharp metal edges.

Using the device

1. ➤ Lift off the lid of the collecting vessel (1) and, moving outwards with a brush, clean the grinding stock from the outer surface of the sieve ring (4) and from the inner edge of the collecting vessel (6). If source material falls downward, it does not directly enter the device; however, this should immediately be vacuumed away with a vacuum cleaner (➔ Chapter 8 'Cleaning' on page 44) after removing the sample.
2. ➤ Remove collecting vessel (6) with the sample.
3. ➤ Use a vacuum cleaner to vacuum away the residual source material.
4. ➤ Remove sieve ring (4) and rotor (5).



It is important to remove the sieve ring (4) and rotor (5) only after removing the sample, because incompletely milled sample material could be on either part. There is a chance that this could find its way into the milled sample and falsify the milling results.

5. ➤ Use a vacuum cleaner once again to vacuum away any residual source material on the labyrinth disk.
6. ➤ Remove labyrinth disk (9).
7. ➤ Clean parts before the next grinding (➔ Chapter 8 'Cleaning' on page 44).

6.5 Grinding with external cooling

For certain source materials, using coolants before milling can be beneficial for comminution. For instance, soft organic materials or special plastics can be made brittle by briefly immersing them in liquid nitrogen or storing them in a freezer before grinding. Protect the source material against condensation – e.g. a plastic bag could keep the source material dry during cooling until grinding.

For highly temperature-sensitive source material, we recommend cooling the source material with liquid nitrogen before milling and then feeding the material into the funnel in very small quantities, e.g. with a spoon spatula.



CAUTION

Wear safety goggles and suitable safety gloves when using liquid nitrogen!



When milling larger amounts (> 20 g) with external cooling, always use the conversion kit.

Dry ice (solid carbon dioxide) can also be used for cooling. Keep in mind that the surface of dry ice often contains frozen condensate, which can potentially clog or contaminate the sieve ring.

6.5.1 External cooling

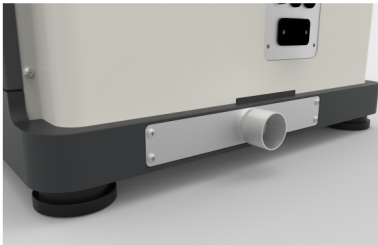

It is possible to exchange the lower ventilation grate on the rear panel against a cover plate (order no. 14.4214.00) with a connector for a vacuum cleaner (order no. 43.9070.00). This will provide faster airflow, thus cooling the system!

6.6 Grinding with heavy-metal-free or metal-free grinding elements

To eliminate the influence of even the smallest amounts of iron, it is necessary to install iron-free grinding elements.

The following parts must be installed:

- **Rotor**
 - Impact rotor made of pure titanium
 - Cutting rotor made of pure titanium
 - Cutting rotor made of zirconium oxide
- **Sieve ring or strainer bowl**
 - Sieve ring with reinforced edges made of pure titanium
 - Strainer bowl, TiN-coated
- **A collecting vessel coated with PTFE,**
- **A lid with titanium insert and PTFE coating.**



When using iron-free grinding elements, keep in mind that the hardness and abrasion resistance of titanium is significantly lower than that of the stainless steel. The Teflon coating of the collecting vessel and lid also has reduced abrasion resistance. (→ Chapter 2.2 'Scope of application' on page 7)



The inner funnels and made of stainless steel may not be used.

Installing and removing the grinding elements

- Carry out the installation and removal of the grinding elements as well as the milling process as described in → Chapter 6.1.3 'Inserting the impact element' on page 26, → Chapter 6.4 'Removing the grinding elements' on page 33 and → Chapter 6.3 'Conducting a grinding operation' on page 33.

6.7 Continuous feeding of source material



The volume of continually fed source material may not exceed the volume of the inserted collecting vessel.

To feed larger quantities of a free-flowing source material, use the vibratory feeder "LABORETTE 24".

- Set the feeder on a stand next to the variable speed rotor mill so that the end of the channel is located above the funnel.
- Connect the devices by plugging the connection cable supplied with the LABORETTE 24 control unit into the connection socket on the back of the PULVERISETTE 14 premium line.



If the motor is overloaded, the sample flow is interrupted. As soon as the source material contained in the grinding chamber has been processed and the motor runs at nominal load, the sample flow is resumed.

The flow of source material on the feeder is regulated via the PULVERISETTE 14 premium line.

The flow of the source material out of the funnel onto the channel of the LABORETTE 24 channel has to be adjusted according to the flow properties of the source material.

- Set the distance between the funnel and the channel by changing the height of the funnel so that the "right" amount is fed.
- If too much is fed, the feeder switches off automatically too often - slide the funnel somewhat downwards.
- If too little is fed, the load display remains in the lowest range - slide the funnel somewhat upwards.

Carry out the installation and removal of the grinding elements as well as the milling process as described in ➔ Chapter 6.1.3 'Inserting the impact element' on page 26, ➔ Chapter 6.4 'Removing the grinding elements' on page 33 and ➔ Chapter 6.3 'Conducting a grinding operation' on page 33.

6.8 Grinding with the impact bar insert

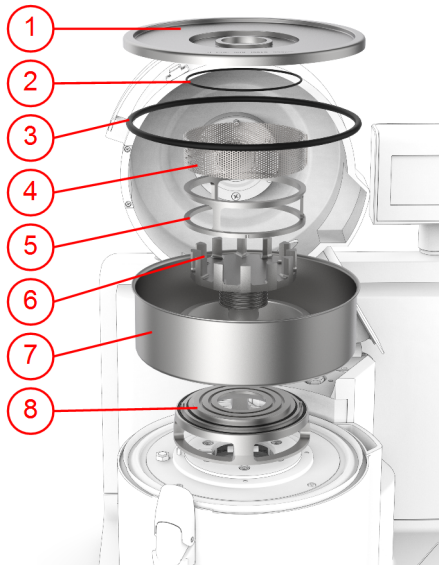

For the item numbers, please refer to our homepage or the spare parts catalogue.

- 1 Collecting vessel lid
- 2 O-ring 98 x 2
- 3 Lid seal
- 4 Sieve ring
- 5 Impact bar
- 6 Rotor
- 7 Collecting vessel
- 8 Labyrinth disk with O-rings

To carry out grinding with a process similar to that of a cross beater mill, there is an optional insert with impact bar (5) and an outer sieve ring (4).

The rotor (6) operates directly next to the impact bar (5). This increases the shear stress on the grinding stock. This provides for faster coarse grinding of brittle grinding stock. Additionally, the temperature load on the grinding stock is significantly lower with fine-grinding.

If an existing rotor will be used, only the impact bar and a matching sieve ring need to be ordered.



Only sieve rings without a reinforced edge may be used for grinding with the impact bar insert.

The handling of the impact bar insert is the same as for the standard grinding elements (see → Chapter 6.1.3 'Inserting the impact element' on page 26, → Chapter 6.4 'Removing the grinding elements' on page 33 and → Chapter 6.3 'Conducting a grinding operation' on page 33). The sieve ring is just replaced with the impact bar (5) and outer sieve ring (4).

The O-ring (2) serves to seal off the sieve ring (4) from the lid (1) of the collecting vessel. First, the sieve ring (4) is placed over the impact bar (5) and inserted. Then the lid is placed on the collecting vessel.

In addition to the 6-blade rotor, the 12- or 24-rib rotors may also be employed. For the order numbers of the different sieve rings, please refer to the spare parts drawing.

6.9 Factors with an impact on grinding

Source material feed rate	The smaller the feed rate of source material, the larger the share of fine particles and the circulation of air. The mechanical and temperature load on the mill decrease. Optimal feeding largely depends on the sample and volume and should be determined in preliminary tests.
Speed	Higher speeds shorten the grinding time and increase the share of fine particles. The mechanical and temperature load on the mill increase exponentially with increasing speed.
Size of sieve perforation	The smaller the perforation of the sieve, the slower the sample has to be fed and the longer the milling time. The noise level decreases with finer perforation.
Cooling	Effective cooling (e.g. by using a cyclone separator) always has benefits for grinding and mill.
Rotor	The use of the various rotors depends on the consistency of the samples, potential temperature changes and the desired grinding result. A practical test is recommended to determine the suitable rotor for your application.

6.10 Control panel



When the mill is switched on, the values of the last grinding are displayed. Other parameters can be selected by clicking on the *[Menu]* button in order to change the following settings:

- Parameter: Speed settings from 6000 - 22000 (rpm), selectable in steps of 1000. Time, depending on which settings are selected for the timer functions. Time frame in minutes, seconds or running a stopwatch.
- Timer functions: You can select various settings in the menu for these functions.
 - Internal clock: This specifies the time that is set as the duration of the grinding process. This grinding time can be interrupted at any time by pressing the *[Stop]* button.
 - min / sec mode: By clicking the *[min mode]* button, you can select if the set grinding time is to be measured in minutes or seconds. When the "min mode" shows, this has been set to minutes. When the "sec mode" shows, it has been set to seconds.
 - Stopwatch: When the stopwatch is activated, the time required for the grinding process is stopped when the grinding process is started. When "Stopwatch" has been activated in the parameter settings, the time unit of min or sec cannot be influenced.
- Language: Here you can set various languages.
- Info: This shows information on the version of the device's software, the total run-time and the temperature at the labyrinth disk.
- Vacuum cleaner OFF: If a dust exhaust system has been connected to the back side of the PULVERISETTE 14 premium line in combination with the switchbox (86.5500.00), the dust exhaust system can be switched on by this button. This function is used for example after a comminution process for exhausting the sample material remaining in the grinding chamber.

This function does not influence the switching characteristics during a grinding.

The start screen shows the set speed or the current speed during the grinding process. In addition, the set time is displayed in the timer functions menu item. The temperature measured at the labyrinth disk and the load bar for the motor are also displayed.

7 Accessories

7.1 High-performance cyclone separator

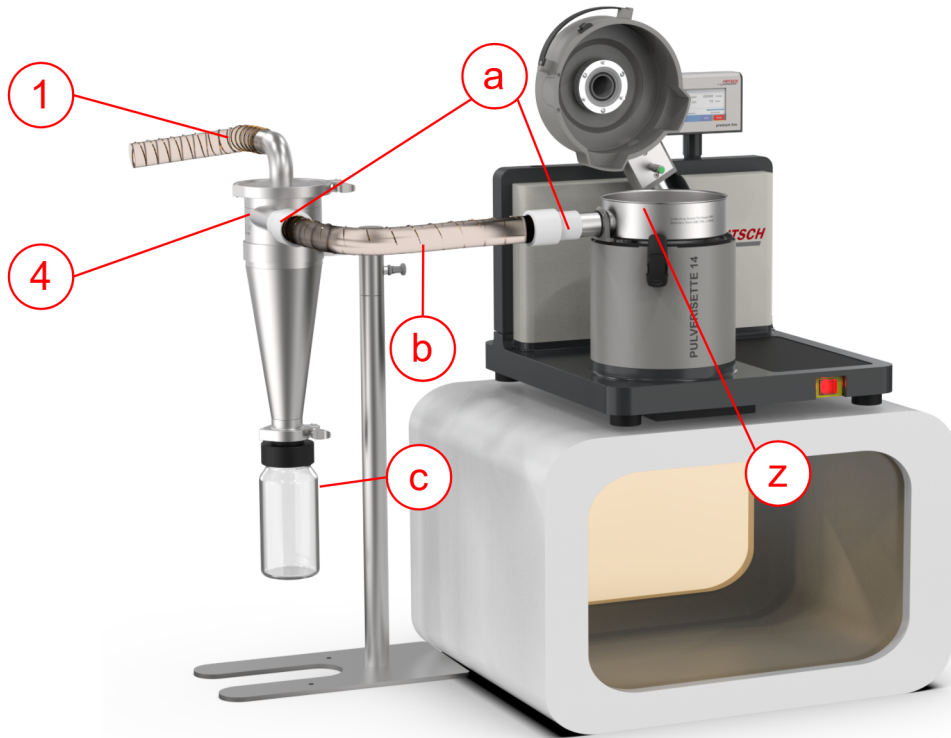

- 1 Dust exhaust connection
- 4 Mill connection
- a 2 x bushing for spiral hose (45.5984.16)
- b 1x hose sample exhaustion (45.5979.16)
- c 1x sample bottle 1000 ml (83.3250.00)
- z Collecting vessel for sample exhaustion with cyclone separator (optional accessory)

The high-performance cyclone separator is suited for sample materials that are sensitive to temperatures. The strong air flow cools the device on one hand and on the other hand allows inserting much finer sieves for greater final fineness because a faster throughput takes place.

A more detailed description of the handling of the high-performance cyclone separator can be found in the cyclone separator's operating manual.



NOTICE

During the grinding process, use the Cyclone exhaust system to ensure that the air flows freely through the funnel:

- Choose a sample quantity that will not clog the funnel.
- Do not use an inner funnel. (classic line)
- Do not cover the funnel with your hand.

If these points are not observed, negative pressure is generated in the grinding chamber and the rotor is pulled upwards after the exhaust system is switched on. This can cause damage to the lid of the collecting vessel.

Working with the sample exhaust system

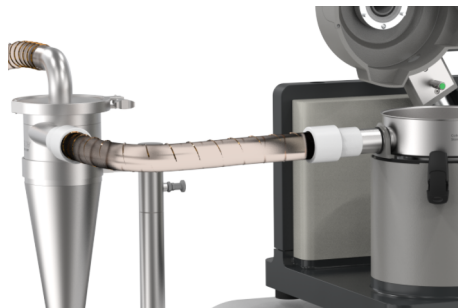

1. Slide the bushing with the spiral hose from the cyclone separator over the outlet of the grinding vessel.

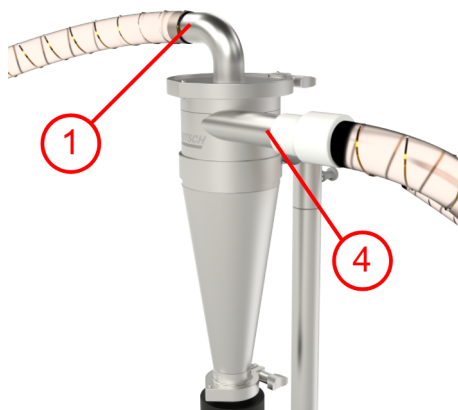

2. Fasten the other end of the exhaust hose on the connector (4) of the cyclone separator.
3. Screw the sample bottle onto the adapter on the bottom of the cyclone separator, making sure the exhaust hose (1) is firmly connected.
4. PULVERISETTE 14 premium line should be switched on.



NOTICE

During the grinding process, use the Cyclone exhaust system to ensure that the air flows freely through the funnel:

- Choose a sample quantity that will not clog the funnel.
- Do not use an inner funnel. (classic line)
- Do not cover the funnel with your hand.

If these points are not observed, negative pressure is generated in the grinding chamber and the rotor is pulled upwards after the exhaust system is switched on. This can cause damage to the lid of the collecting vessel.

5. Switch on the exhaust system.
6. Start sample feeding.

7.2 Small volume Cyclone separator



We recommend using an additional exhaust system for employing the small volume cyclone separator with the PULVERISETTE 14 premium line.



Two different fine dust filters are included with the small volume cyclone separator as accessories. The coarser filter has a pore size of 80 µm; the finer one can be used for particles to a minimum of 40 µm. The finer fine dust filter clogs up quicker with courser material.

Especially with brittle and fine sample materials it can happen that sample material can even pass through the fine 40 µm filter anyway. Should sample material escape massively, then the application may possibly be only suitable for a closed system without small volume cyclone separator.

In case a sterilisation is necessary, Fritsch recommends soaking the filters in 100 % isopropanol for an hour and then air-drying for at least 12 hours.

A cleaning can be done with compressed air as well as with detergents and lukewarm water with subsequent air-drying. Cleaning in dishwashers or mechanically would cause damage to the filters. Generally Fritsch recommends exchanging the filters regularly.

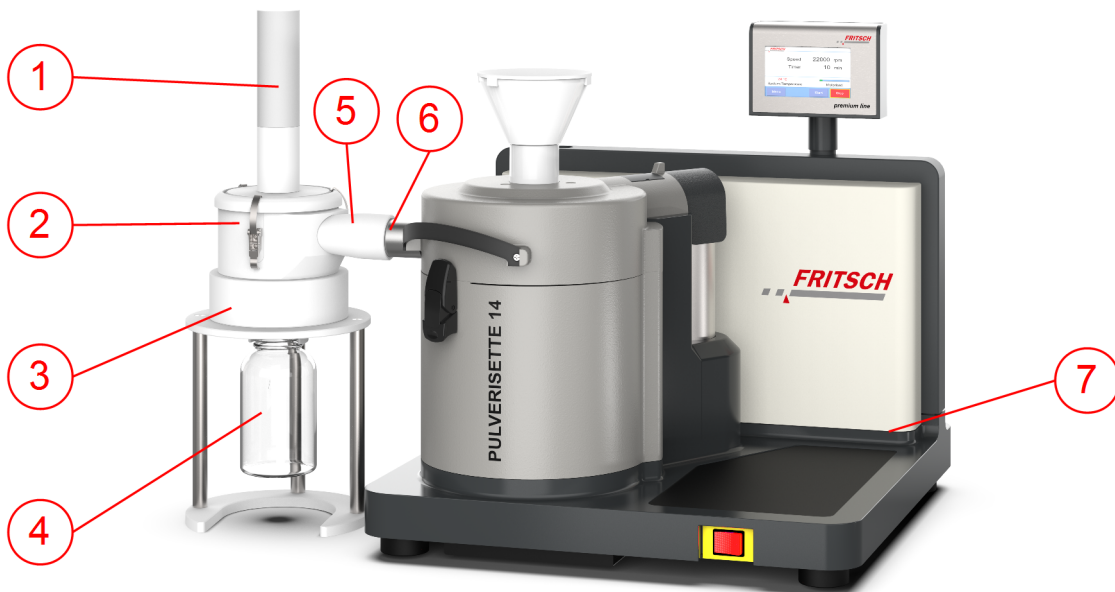

- | | | | |
|---|--------------------------------|---|-------------------|
| 1 | Fine dust filter | 3 | Spacer ring |
| 2 | Small volume cyclone separator | 4 | Collecting vessel |

- 5 Particle inlet pipe for connecting to the collecting vessel
- 6 Outlet pipe, collecting vessel
- 7 PULVERISETTE 14 *premium line*



The small volume Cyclone separator can be used for the sample exhaustion of small sample quantities!

- 1.** ➤ Connect all parts as shown in the previous image.
- 2.** ➤ Switch on the exhaust system.
- 3.** ➤ Switch on the PULVERISETTE 14 premium line.
- 4.** ➤ Add the sample in small amounts into the funnel.
- 5.** ➤ As soon as the collecting vessel underneath the small volume Cyclone separator is 3/4 full, stop adding the sample and empty or replace the collecting vessel!

8 Cleaning



! DANGER

Mains voltage!

- Before beginning with cleaning work, disconnect the mains plug and protect the device against being unintentionally switched back on!
- Do not allow any liquids to flow into the device.
- Indicate cleaning work with warning signs.
- Put safety equipment back into operation after cleaning work.

8.1 Device

The outside of the device can be cleaned with a soft, damp cloth when it is in the switched off state.

Do not use solvents for cleaning.

8.2 Grinding chamber

The type and frequency of thorough cleaning depends on source material and its final fineness. We recommend regular checks at the beginning in order to adjust the cleaning intervals for the use of the variable speed rotor mill.

Residual source material beneath the labyrinth disk or in the area around the motor mount must be carefully and completely vacuumed away - if necessary, use a brush or vacuum cleaner brush for the final touch-up.

The collecting vessel, rotor, sieve and labyrinth disk should be thoroughly cleaned outside of the variable speed rotor mill - they may be brushed off when wet or cleaned in the ultrasonic cleaner "LABORETTE 17".

The inner funnel can be removed for cleaning and the outer funnel can be unscrewed.

When cleaning the grinding elements, make sure that all guiding surfaces with gliding movements are cleaned. These surfaces can also be lightly oiled.

Caution when cleaning the grinding elements:

The rotor and sheet metal parts such as sieves and the collecting vessel can have sharp edges. For this reason, wear gloves that are safe and without defect.

9 Maintenance



DANGER

Mains voltage

- Before beginning with maintenance work, unplug the mains plug and protect the device against being unintentionally switched back on again!
- Indicate maintenance work with warning signs.
- Maintenance work may only be performed by specialised personnel.
- Put safety equipment back into operation after maintenance or repair work



We recommend keeping a safety logbook → Chapter 14 'Safety logbook' on page 52, where all work (maintenance, repairs.....) performed on the device is entered.



The most important element of maintenance is regular cleaning!

9.1 Intake filter

On the base of the PULVERISETTE 14 premium line, the intake area for cool air entering the device is protected with a filter mat so that only relatively dust-free cooling air is taken into the device.



NOTICE

Maintenance of this filter mat is absolutely required. The drive motor is not sufficiently cooled when the filter mat is excessively soiled. This results in motor failure.

To check the filter mat, proceed as follows:

1. → Turn the PULVERISETTE 14 premium line over onto the left side of the housing.
2. → Loosen the 4 hexagon screws holding the filter mat.
3. → Remove the filter mat and rinse it under running water. Thoroughly dry the filter mat before remounting it.



If the filter mat is heavily soiled or damaged, replace it with a new one. (Order no. 14.4103.00)

10 Repairs



 **DANGER**

Mains voltage!

- Before beginning with repair work, unplug the mains plug and protect the device against being unintentionally switched back on.
- Indicate repair work with warning signs.
- Repair work may only be performed by specialised personnel.
- Put safety equipment back into operation after maintenance work.

11 Disposal

It is hereby confirmed that FRITSCH has implemented the directive 2002/95/EC of the European Parliament and Council from 27th January 2003 for the limitation of the use of certain dangerous substances in electrical and electronic devices.

FRITSCH has registered the following categories according to the German electrical and electronic equipment act, section 6, paragraph 1, clause 1 and section 17, paragraphs 1 and 2:

Mills and devices for the preparation of samples have been registered under category 6 for electrical and electronic tools (except for large stationary industrial tools).

Analytical devices have been registered under category 9, monitoring and control instruments.

It has been accepted that FRITSCH is operating only in the business-to-business area. The German registration number for FRITSCH is WEEE reg. no. DE 60198769

FRITSCH WEEE coverage

Since the registration of FRITSCH is classified for bilateral transactions, no legal recycling or disposal process is described. FRITSCH is not obliged to take back used FRITSCH devices.

FRITSCH declares it is prepared to take back used FRITSCH devices for recycling or disposal free of charge whenever a new device is purchased. The used FRITSCH device must be delivered free of charge to a FRITSCH establishment.

In all other cases FRITSCH takes back used FRITSCH devices for recycling or disposal only against payment.

12 Guarantee terms

Guarantee period

As manufacturer, FRITSCH GmbH provides – above and beyond any guarantee claims against the seller – a guaranty valid for the duration of two years from the date of issue of the guarantee certificate supplied with the device.

Within this guarantee period, we shall remedy all deficiencies due to material or manufacturing defects free of charge. Rectification may take the form of either repair or replacement of the device, at our sole discretion. The guarantee may be redeemed in all countries in which this FRITSCH device is sold with our authorisation.

Conditions for claims against the guarantee

This guarantee is subject to the condition that the device is operated according to the instructions for use / operating manual and its intended use.

Claims against the guarantee must include presentation of the original receipt, stating the date of purchase and name of the dealer, together with the complete device type and serial number.

For this guarantee to take effect, the answer card entitled "Securing of Guarantee" (enclosed with the device) must be properly filled out and despatched without delay after receipt of the device and be received by us within three weeks or alternatively, ➔ *online registration* must be carried out with the above-mentioned information.

Reasons for loss of the guarantee

The guarantee will not be granted in cases where:

- Damage has arisen due to normal wear and tear, especially for wear parts, such as: Crushing jaws, support walls, grinding bowls, grinding balls, sieve plates, brush strips, grinding sets, grinding disks, rotors, sieve rings, pin inserts, conversion kits, sieve inserts, bottom sieves, grinding inserts, cutting tools, sieve cassettes, sieve and measuring cell glasses.
- Repairs, adaptations or modifications were made to the device by unauthorized persons or companies.
- The device was not used in a laboratory environment and/or has been used in continuous operation.
- Damage is present due to external factors (lightning, water, fire or similar) or improper handling.
- Damage is present that only insubstantially affects the value or proper functioning of the device.
- The device type or serial number on the device has been changed, deleted, removed or in any other way rendered illegible
- The above-mentioned documents have been changed in any way or rendered illegible.

Costs not covered by the guarantee

This guarantee excludes any costs for transport, packaging or travel that accrue in the event the product must be sent to us or in the event that one of our specialist technicians is required to come to your site. Any servicing done by persons not authorised by us and any use of parts that are not original FRITSCH accessories and spare parts will void the guarantee.

Further information about the guarantee

The guarantee period will neither extend nor will a new period of guarantee begin in the event that a claim is placed against the guarantee.

Please provide a detailed description of the type of error or the complaint. If no error description is enclosed, we shall interpret the shipment as an assignment to remedy all recognisable errors or faults, including those not covered by the guarantee. Errors or faults not covered by the guarantee shall in this case be rectified at cost.

We recommend reading the operating manual before contacting us or your dealer, in order to avoid unnecessary inconvenience.

Ownership of defective parts is transferred to us with the delivery of the replacement part; the defective part shall be returned to us at buyer's expense.

**NOTICE**

Please note that in the event that the device must be returned, the device must be shipped in the original Fritsch packaging. Fritsch GmbH denies all liability for any damage due to improper packaging (packaging not from Fritsch).

Any enquiries must include a reference to the serial number imprinted on the type plate.

13 Exclusion of liability

Before using the product, be sure to have read and understood this operating manual.

The use of the product requires technical knowledge; only commercial use is permitted.

The product may be used exclusively within the scope of applications set down in this operating manual and within the framework of guidelines put forth in this operating manual and must be subject to regular maintenance. In case of non-compliance, improper use or improper maintenance, the customer assumes full liability for the functional capability of the product and for damage or injury arising from violating these obligations.

The contents of this operating manual are subject in entirety to copyright law. This operating manual and its contents may not be copied, further distributed or stored in any form, in part or in whole, without the prior written consent of Fritsch.

This operating manual has been prepared to the best of our knowledge and checked for accuracy at the time of printing. FRITSCH GMBH assumes no guarantee or liability whatsoever for the accuracy or completeness of the contents of this operating manual, including but not limited to the implied warranties of merchantability and fitness for a particular purpose, unless liability is expressly prescribed by applicable laws or jurisprudence.

FRITSCH GMBH expressly reserves the right to modify and/or update this operating manual without prior notice. The same applies to modifications and improvements to the products described in this operating manual. It is the responsibility of the user to ensure that they have the current version of this operating manual. For more information, please contact your local FRITSCH GMBH distributor or Fritsch GmbH, Industriestr. 8, D-55473 Idar-Oberstein.

Not all parts shown here are necessarily installed in the product. The buyer is not entitled to delivery of these parts. If interested, please contact your local FRITSCH GMBH distributor or Fritsch GmbH, Industriestr. 8, D-55473 Idar-Oberstein.

FRITSCH GMBH takes the greatest care to ensure that the quality, reliability and safety of your products are continuously improved and adapted to the state of the art. The supplied products as well as this operating manual conform to the current state of the art when they leave the sphere of influence of FRITSCH GMBH.

By using the product the customer agrees with this and recognizes that defects, malfunctions or errors cannot be completely excluded. To prevent risk of damage to persons or property or of other direct or indirect damage, resulting from this or other causes, the customer must implement sufficient and comprehensive safety measures for working with the product.

Fritsch GmbH excludes any liability, warranty, or other obligation to compensate for damages, regardless of whether this liability, warranty, or other obligation is explicit or implicit, contractual or arising from unlawful acts or prescribed contractually, by law, or otherwise. In no event shall the buyer be entitled to any compensation from Fritsch GmbH for any special, direct, indirect, coincidental or consequential damage, including but not limited to lost profits, lost savings, lost sales or financial loss of any kind or for compensation of third parties, for downtimes, for lost goodwill, for damage to or replacement of equipment and property, for costs or restoration of materials or goods related to the product or the use of our products, for other damage or injury to persons (including fatal

injuries) or similar. The above exclusion of liability is limited by mandatory liability as prescribed by laws or jurisprudence. Liability for negligence is excluded in all cases.

No permission is given expressly, implicitly or otherwise for the use of patents, brands or other copyrights. We also assume no liability for copyright infringements or infringements of the rights of third parties arising from the use of this product.

Neither compliance with this operating manual nor the conditions and methods used during installation, operation, use and maintenance of the product can be monitored by Fritsch GmbH. Improper execution of the installation can result in property damage and thus endanger persons. Therefore, we assume absolutely no responsibility or liability for loss, damage or costs that result from errors at installation, improper operation or improper use or improper maintenance or are in any way connected to these.

15 Index

A		M	
Accident prevention.	7	Maintenance.	45
Authorised persons.	7	Material	
C		Feed quantity.	15
Cleaning.	44	Feed size.	15
Device.	44	O	
Grinding chamber.	44	Operating noise level.	15
Intake filter.	45	P	
Control panel.	39	Power consumption.	15
Cutting insert.	29	R	
Cutting rotor.	28	Requirements for the user.	7
D		Rotor.	25
Dimensions.	15	S	
Disposal.	47	Safety information.	9
E		Safety logbook.	52
Electrical connection.	22	Scope of delivery.	17
Emergency release.	13	Setting up.	18
Exclusion of liability.	50	Sieve ring.	26
Explanation of signs.	9	Skilled workers.	7
Explanation of symbols.	9	Standstill.	23
F		Stopping the device.	23
Functional check.	23	Switching on.	23
G		U	
Grinding elements		Unpacking.	17
metal-free.	35	Using the device.	24
Removing.	33	V	
Grinding parts		Voltage.	15
Installing.	26	W	
Grinding process.	33	Warning information.	9
Influencing factors.	38	WEEE.	47
With external cooling.	34	Weight.	15
with impact bar insert.	37		
with metal-free grinding elements.	35		
Grinding stock			
continuous feeding.	36		
Guarantee terms.	48		
I			
Influencing factors			
Cooling.	38		
sieve perforation size.	38		
Source material feed rate.	38		
Speed.	38		
Initial start-up.	23		



© 2019

Fritsch GmbH

Milling and Sizing

Industriestrasse 8

D - 55743 Idar-Oberstein

Telephone: +49 6784 70-0

Email: info@fritsch.de

Internet: www.fritsch.de
